

WIRING DIAGRAMS
Article Text
 1992 Volkswagen GTI
 For Volkswagen Technical Site
 Copyright © 1998 Mitchell Repair Information Company, LLC
 Tuesday, December 07, 1999 10:48PM

ARTICLE BEGINNING

1992 WIRING DIAGRAMS
 Volkswagen Wiring Diagrams

Volkswagen; Golf & GTI

COMPONENT LOCATION MENU

COMPONENT LOCATIONS TABLE

AA

Component	Figure No. (Location)
A/C COMP CLUTCH	6 (C 23)
A/C SWITCH	6 (E 20-21)
A/T CONSOLE LIGHT	4 (C 12), 4 (C 14)
ALTERNATOR	1 (C 3)
BACK-UP LT SW	8 (E 28)
BATTERY	1 (A 2)
BEAM SELECT SWITCH	6 (A 20), 6 (A 22)
BLOWER RESISTOR	4 (B 15)
BRAKE FLUID LEVEL SWITCH	8 (B 31)
CIG LIGHTER	7 (A 24)
CIS-E MOTRONIC CONTROL UNIT	3 (A-C 11)
COOLANT LOW LEVEL SENDER	7 (B 27)
COOLANT TEMP SENDER	7 (A-B 27)
CRUISE CONTROL	4 (D-E 12-15)
DEFOGGER SWITCH	8 (E 29)
DIAG CONN (CALIF)	2 (C 7)
DIAG CONN (GTI 16V)	3 (D 11)
DIGIFANT CONTROL UNIT (CALIF)	2 (A-B 7)
DIGIFANT CONTROL UNIT (EX CALIF)	2 (D-E 7)
DIR SWITCH	6 (A 21), 6 (A 23)
DOOR SWITCHES	7 (A 25-26)
EMERGENCY FLASHER SWITCH	6 (A 20-22), 6 (A 23)
FOG LIGHT SWITCH	7, 8 (A 27-28)
FRESH AIR CONTROL ILLUM LIGHT	6 (E 22)
FRESH AIR FAN SWITCH (W/ A/C)	6 (E 22)
FRESH AIR FAN SWITCH (W/O A/C)	4 (A 15)
FUEL INJECTORS	2 (A 5), 2 (E 5)
FUEL PUMP	5 (E 19)
FUEL TANK UNIT	5 (E 19)
FUSE/RELAY PANEL	5, 6, 7, 8 (C 16-31)
FUSE/RELAY PANEL LAYOUT	7 (A-B 12-14)
GEAR SELECT SWITCH	4 (C 13), 4 (C 14)
GLOVE COMPT LIGHT	7 (E 27)
IGNITION BOOSTER	2 (C 4), 3 (E 11)
IGNITION COIL	2 (D 7)
IGNITION SW	5 (A 16)
INSTRUMENT CLUSTER	9 (A-C 32-33)
INTERIOR LIGHT DELAY SWITCH	7 (A 24-25)
LEFT FRONT DOOR SWITCH	7 (B 26)

WIRING DIAGRAMS
Article Text (p. 2)
1992 Volkswagen GTI
For Volkswagen Technical Site
Copyright © 1998 Mitchell Repair Information Company, LLC
Tuesday, December 07, 1999 10:48PM

LIGHT SWITCH	5 (A-B 18-19)
LUGGAGE COMPT LIGHT	9 (D 35)
MAIN HEATER FUSE	6 (D 21)
MEMORY SWITCH	8 (A 28)
MIRROR HEATERS	9 (C 34)
O2 SENSOR	2 (B 4), 2 (C 5), 3 (B 8)
OIL PRESSURE SWITCHES	7 (A 27)
OIL TEMP SENSOR	8 (B 28)
OUTSIDE AIR TEMP SENSOR	8 (B 28)
PARK BRAKE SWITCH	8 (B 31)
POWER MIRRORS	9 (B-C 33-34)
POWER SEATS	9 (A-B 34)
POWER WINDOWS	9 (D-E 32-34)
RADIATOR COOLING FAN (W/ A/C)	6 (D 20)
RADIATOR COOLING FAN (W/O A/C)	1 (E 3)
RAD COOLING FAN AFTER RUN CTRL UNIT	1 (D 3)
RADIO (PARTIAL)	4 (B 15)
REAR WIPER SYSTEM	7 (C-E 26-27)
SEAT BELT SWITCH	8 (E 31)
SHIFT LOCK CONTROL UNIT	4 (D 12)
STARTER	1 (A 3)
STARTER INTERLOCK RELAY (W/SHIFT LOCK)	1 (B 3)
STARTER INTERLOCK RELAY (W/O SHIFT LOCK)	8 (E 31)
STOP LT SW	8 (B 30)
VACUUM VENT VALVE	4 (E 13)
VANITY MIRROR	7 (A 25)
W/SHIELD WIPER SYSTEM	7 (C-E 24-26)
WARNING MODULE	8 (A 30-31)
AA	

WIRING DIAGRAMS

WIRING DIAGRAMS
Article Text (p. 3)
 1992 Volkswagen GTI
 For Volkswagen Technical Site
 Copyright © 1998 Mitchell Repair Information Company, LLC
 Tuesday, December 07, 1999 10:49PM

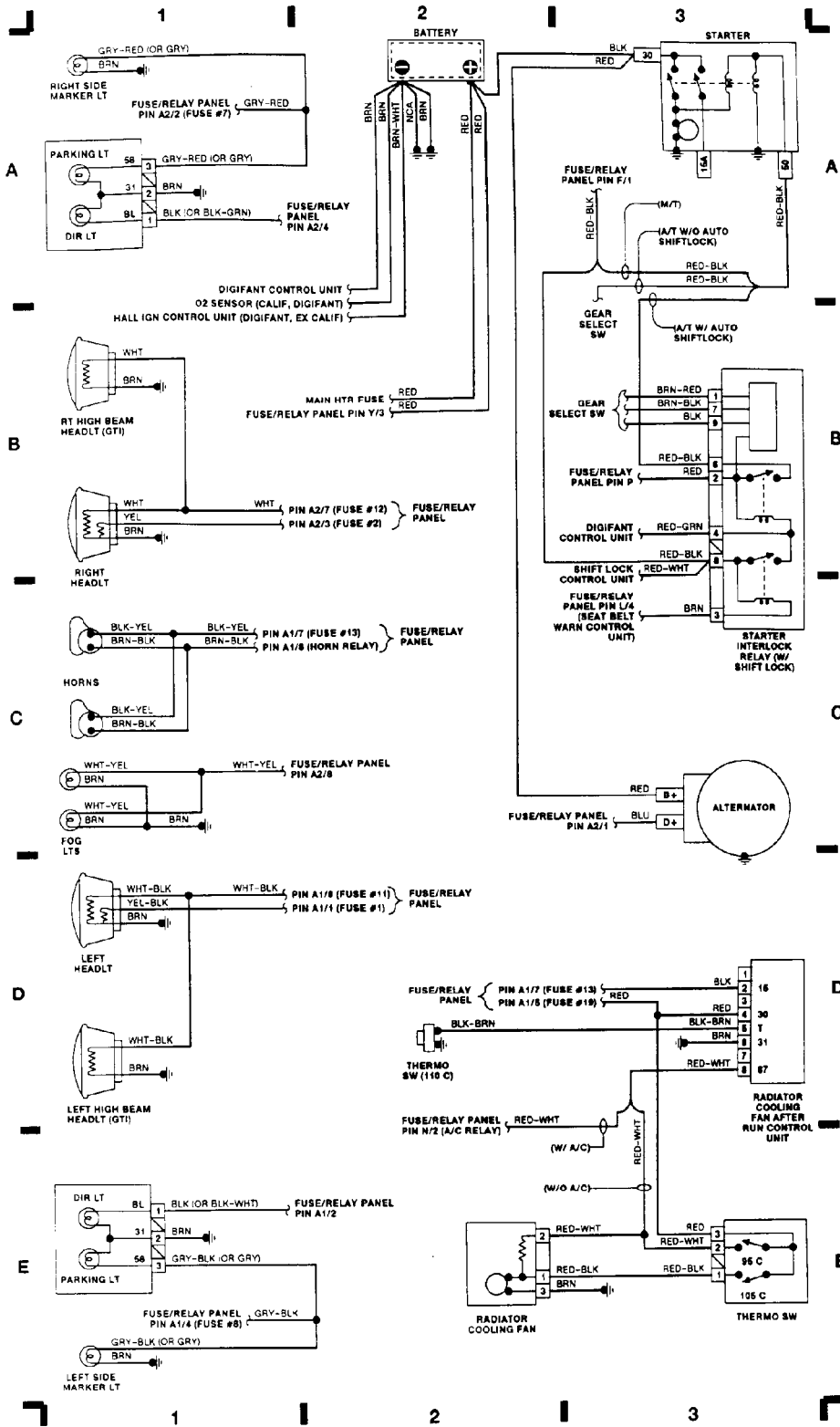

50H01705
 Fig. 1: Engine Compartment & Headlights (Grid 1-3)

WIRING DIAGRAMS
Article Text (p. 4)
 1992 Volkswagen GTI
 For Volkswagen Technical Site
 Copyright © 1998 Mitchell Repair Information Company, LLC
 Tuesday, December 07, 1999 10:49PM

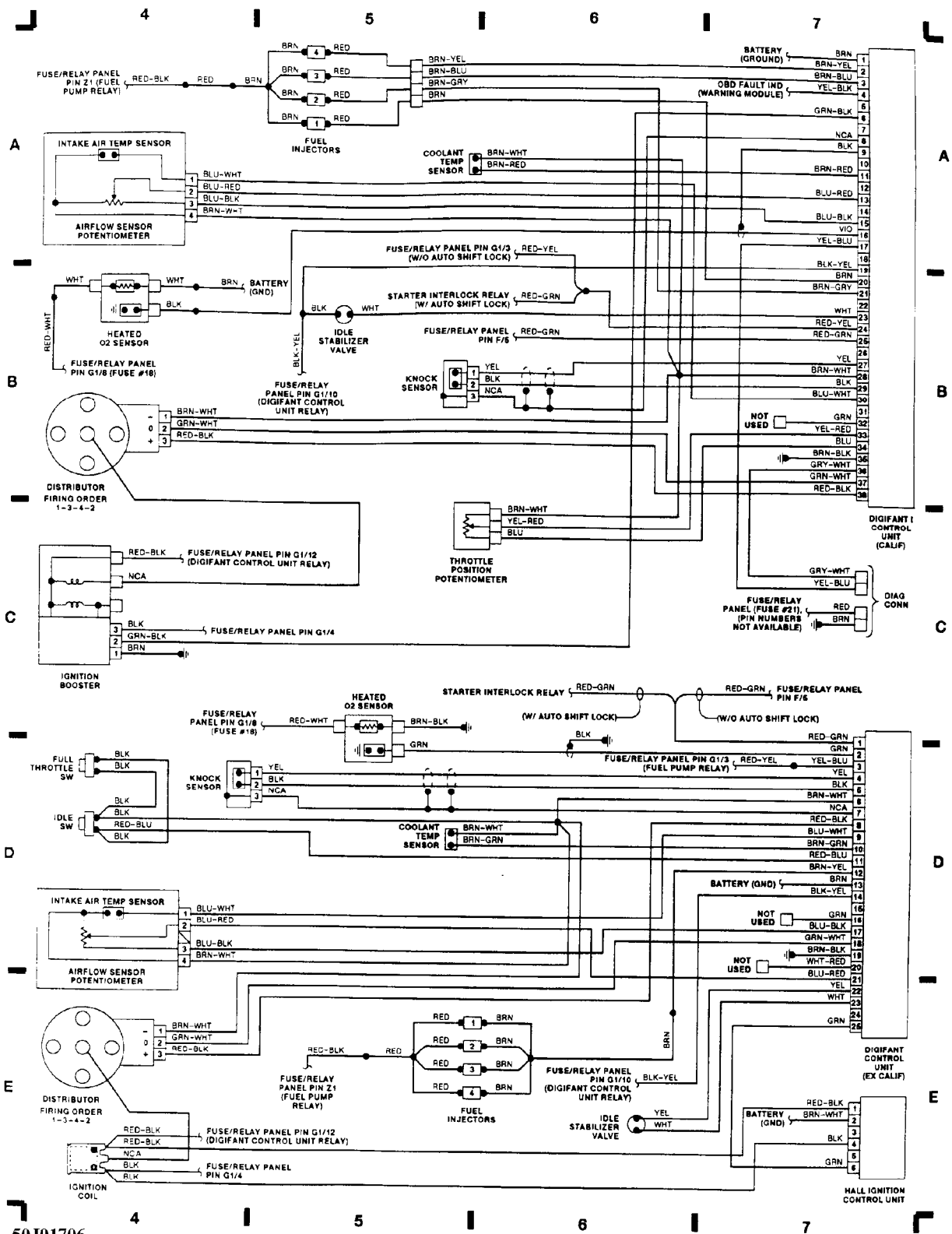
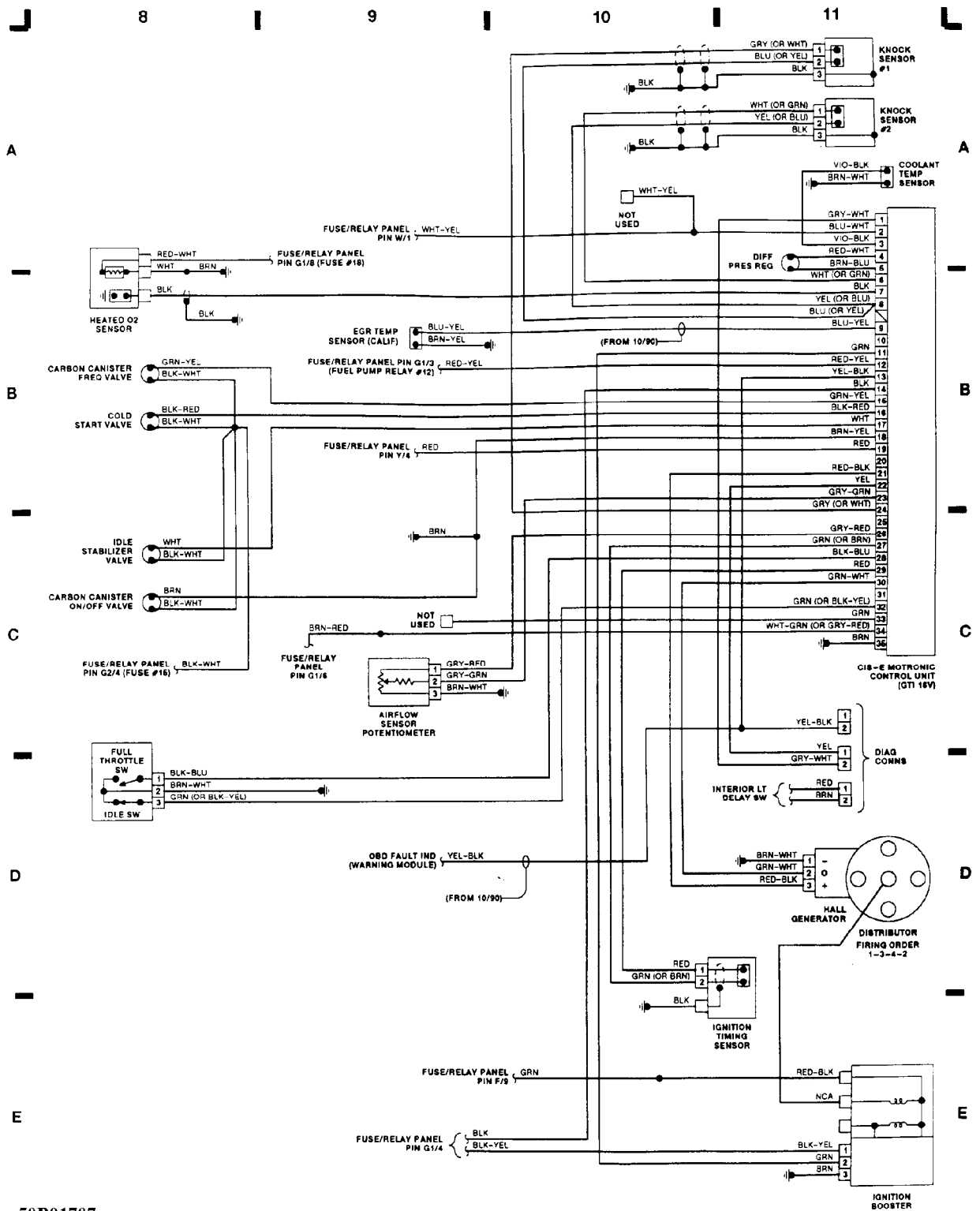

Fig. 2: Fuel Injectors, Digifant Ctrl Unit, (Grid 4-7)

WIRING DIAGRAMS
Article Text (p. 5)
 1992 Volkswagen GTI
 For Volkswagen Technical Site
 Copyright © 1998 Mitchell Repair Information Company, LLC
 Tuesday, December 07, 1999 10:49PM



50B01707

Fig. 3: CIS-E Motronic Ctrl Unit (GTI 16V), (Grid 8-11)

WIRING DIAGRAMS
Article Text (p. 6)
 1992 Volkswagen GTI
 For Volkswagen Technical Site
 Copyright © 1998 Mitchell Repair Information Company, LLC
 Tuesday, December 07, 1999 10:49PM

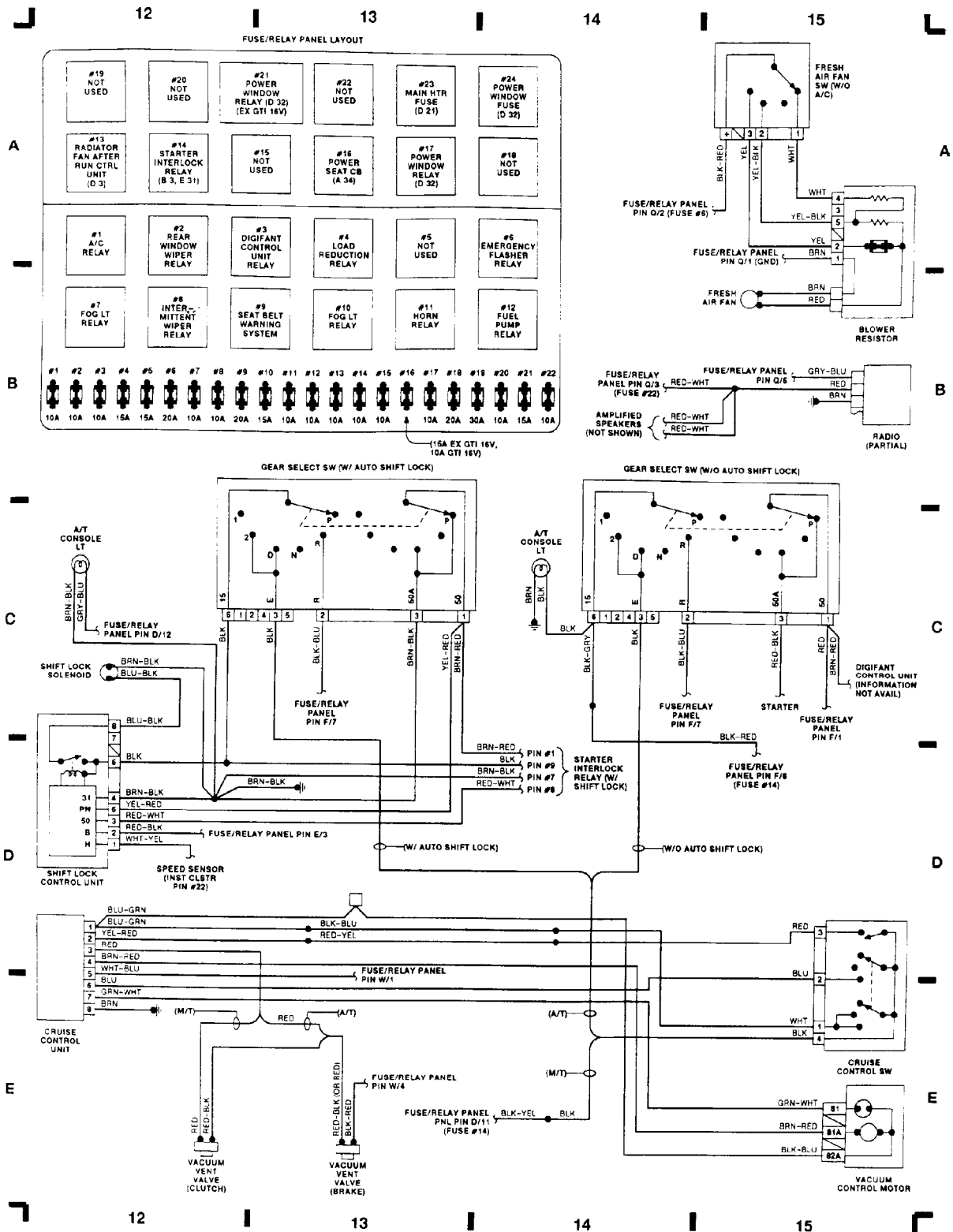
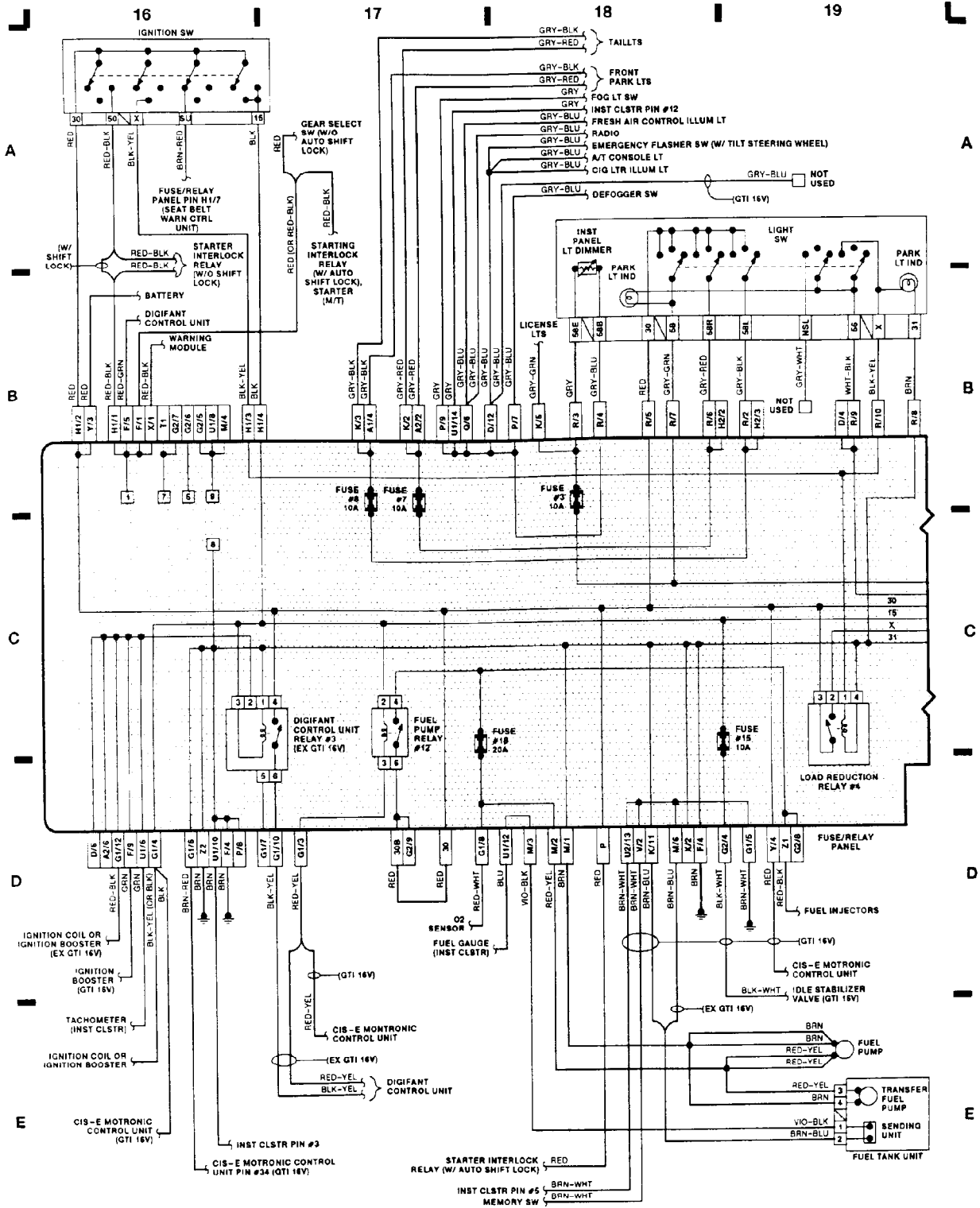

Fig. 4: Fuse/Relay Panel Layout, Gear Select Sw, (Grid 12-15)

50D01708

WIRING DIAGRAMS
Article Text (p. 7)
 1992 Volkswagen GTI
 For Volkswagen Technical Site
 Copyright © 1998 Mitchell Repair Information Company, LLC
 Tuesday, December 07, 1999 10:49PM



50F01709

Fig. 5: Fuse/Relay Panel (1 of 4), Ignition Sw, (Grid 16-19)

WIRING DIAGRAMS
Article Text (p. 8)
 1992 Volkswagen GTI
 For Volkswagen Technical Site
 Copyright © 1998 Mitchell Repair Information Company, LLC
 Tuesday, December 07, 1999 10:49PM

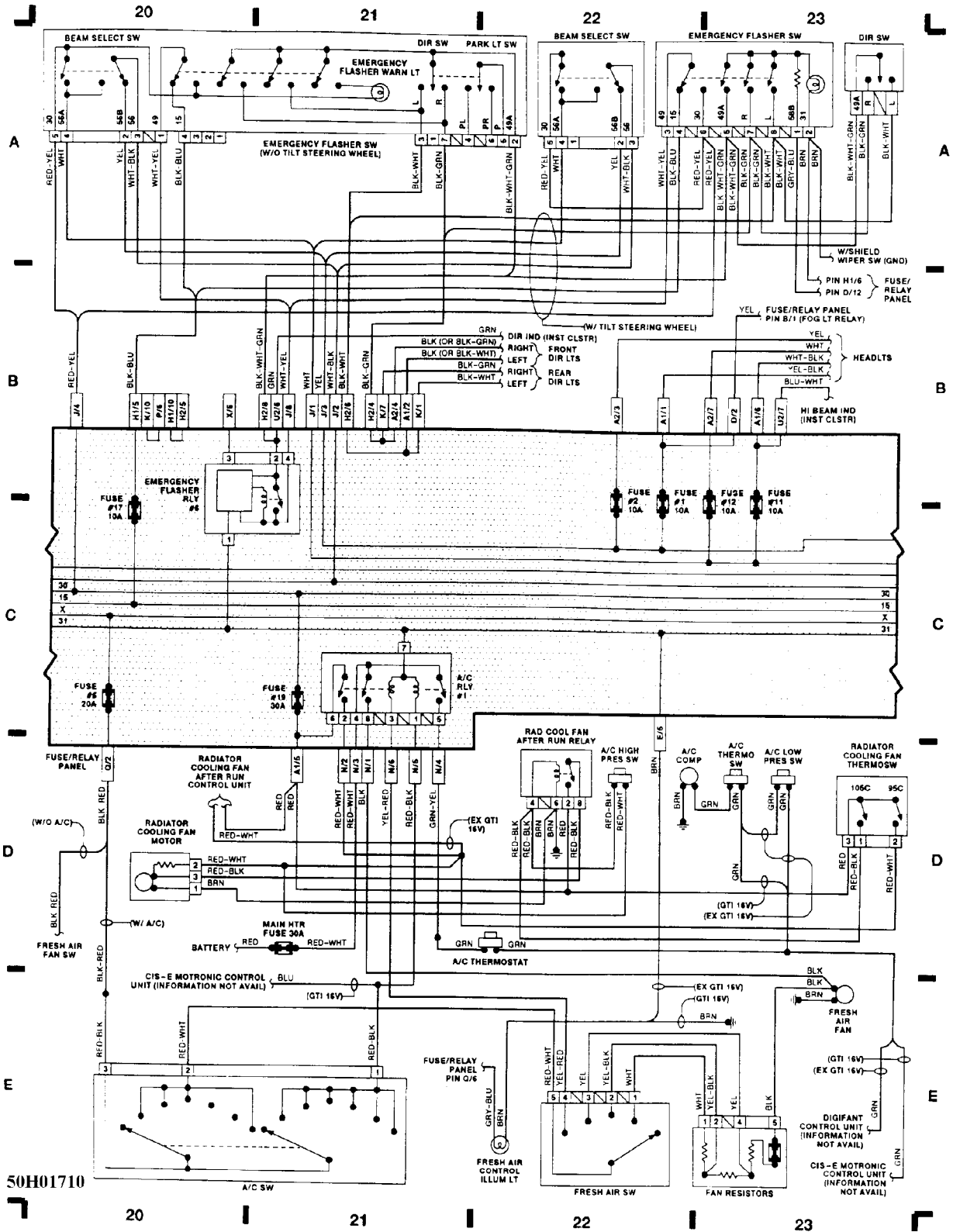

Fig. 6: Fuse/Relay Panel (2 of 4), (Grid 20-23)

WIRING DIAGRAMS
Article Text (p. 9)
 1992 Volkswagen GTI
 For Volkswagen Technical Site
 Copyright © 1998 Mitchell Repair Information Company, LLC
 Tuesday, December 07, 1999 10:49PM

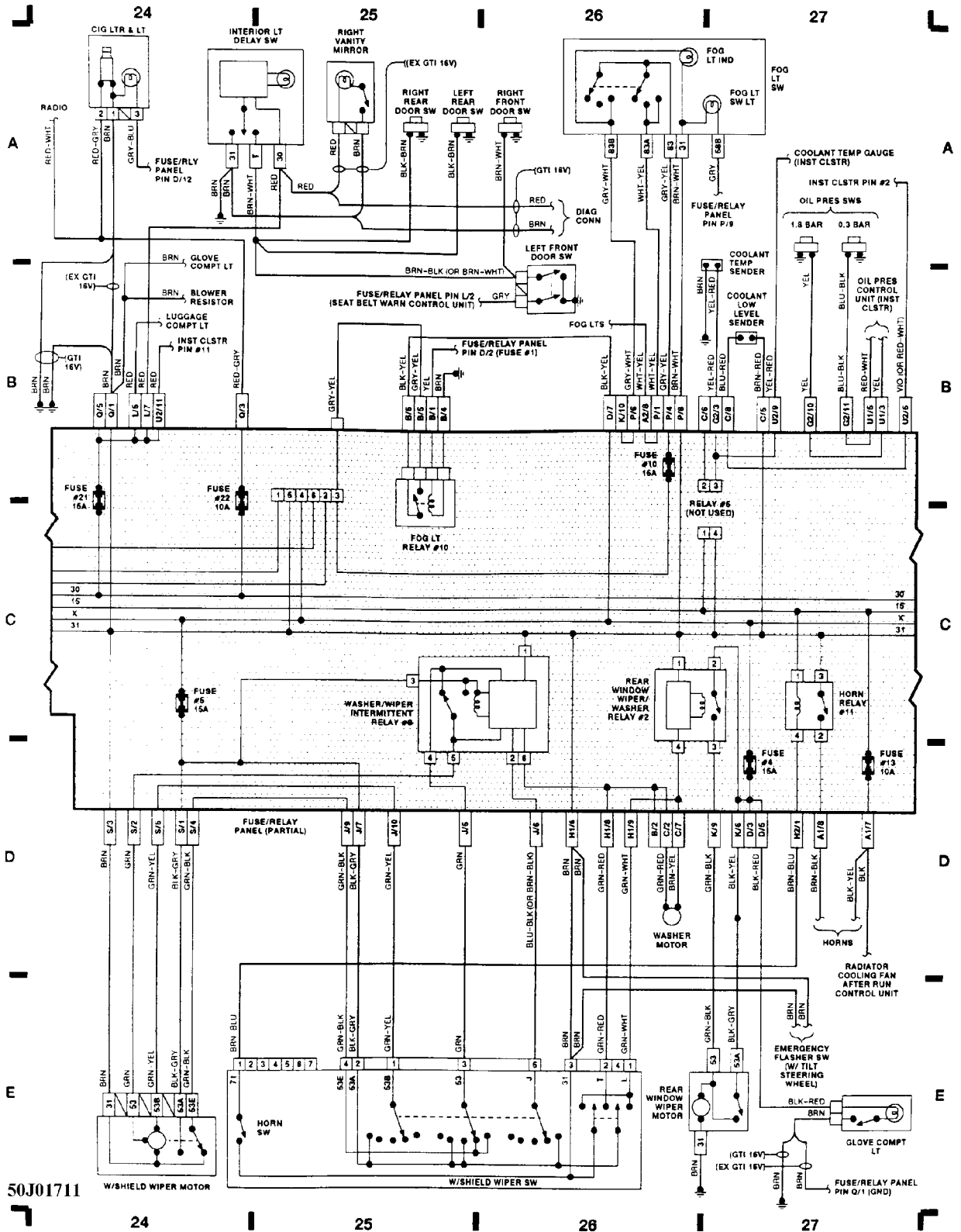
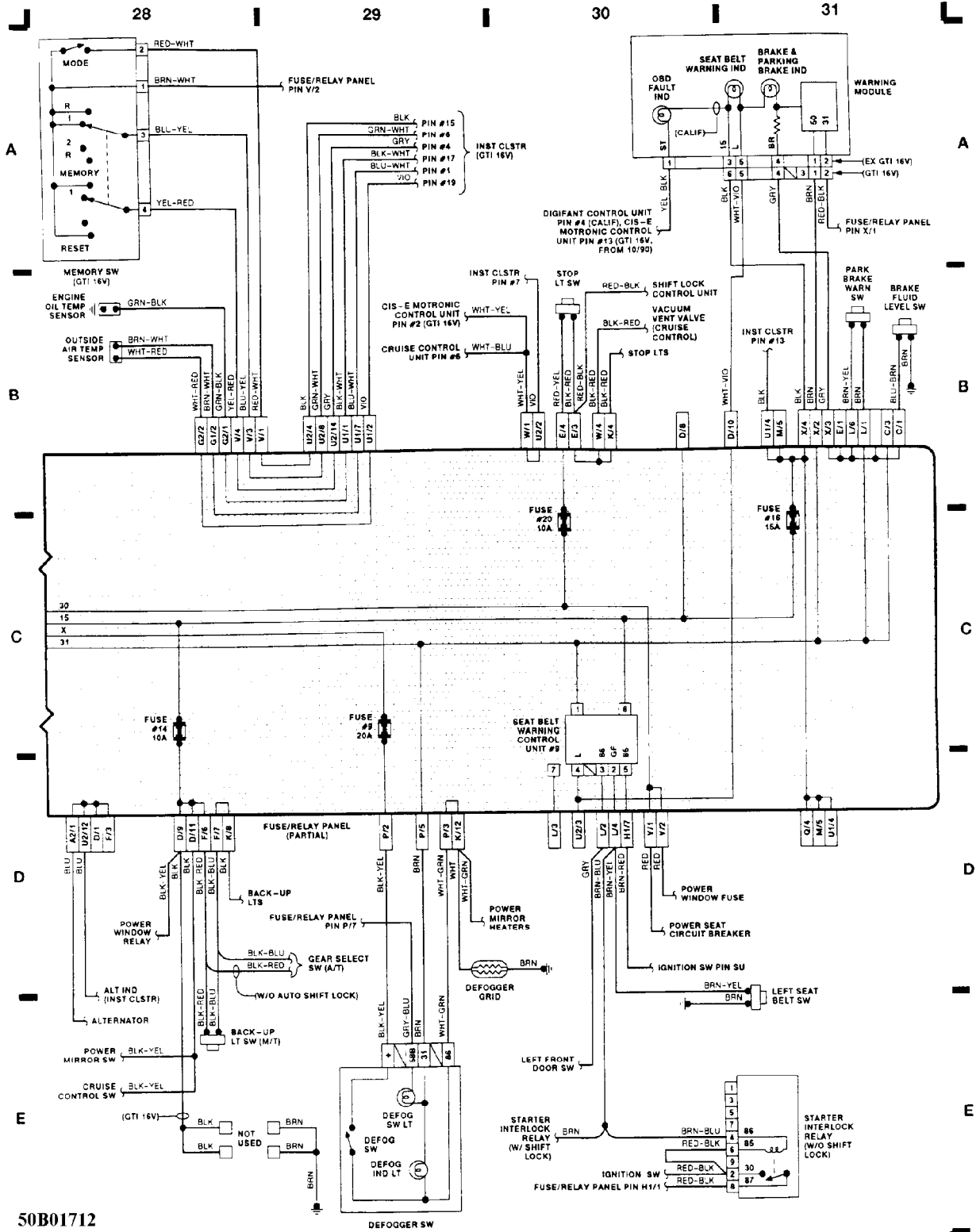

Fig. 7: Fuse/Relay Panel (3 of 4), (Grid 24-27)

WIRING DIAGRAMS
Article Text (p. 10)
 1992 Volkswagen GTI
 For Volkswagen Technical Site
 Copyright © 1998 Mitchell Repair Information Company, LLC
 Tuesday, December 07, 1999 10:49PM



50B01712
 Fig. 8: Fuse/Relay Panel (4 of 4), (Grid 28-31)

WIRING DIAGRAMS
Article Text (p. 11)
 1992 Volkswagen GTI
 For Volkswagen Technical Site
 Copyright © 1998 Mitchell Repair Information Company, LLC
 Tuesday, December 07, 1999 10:49PM

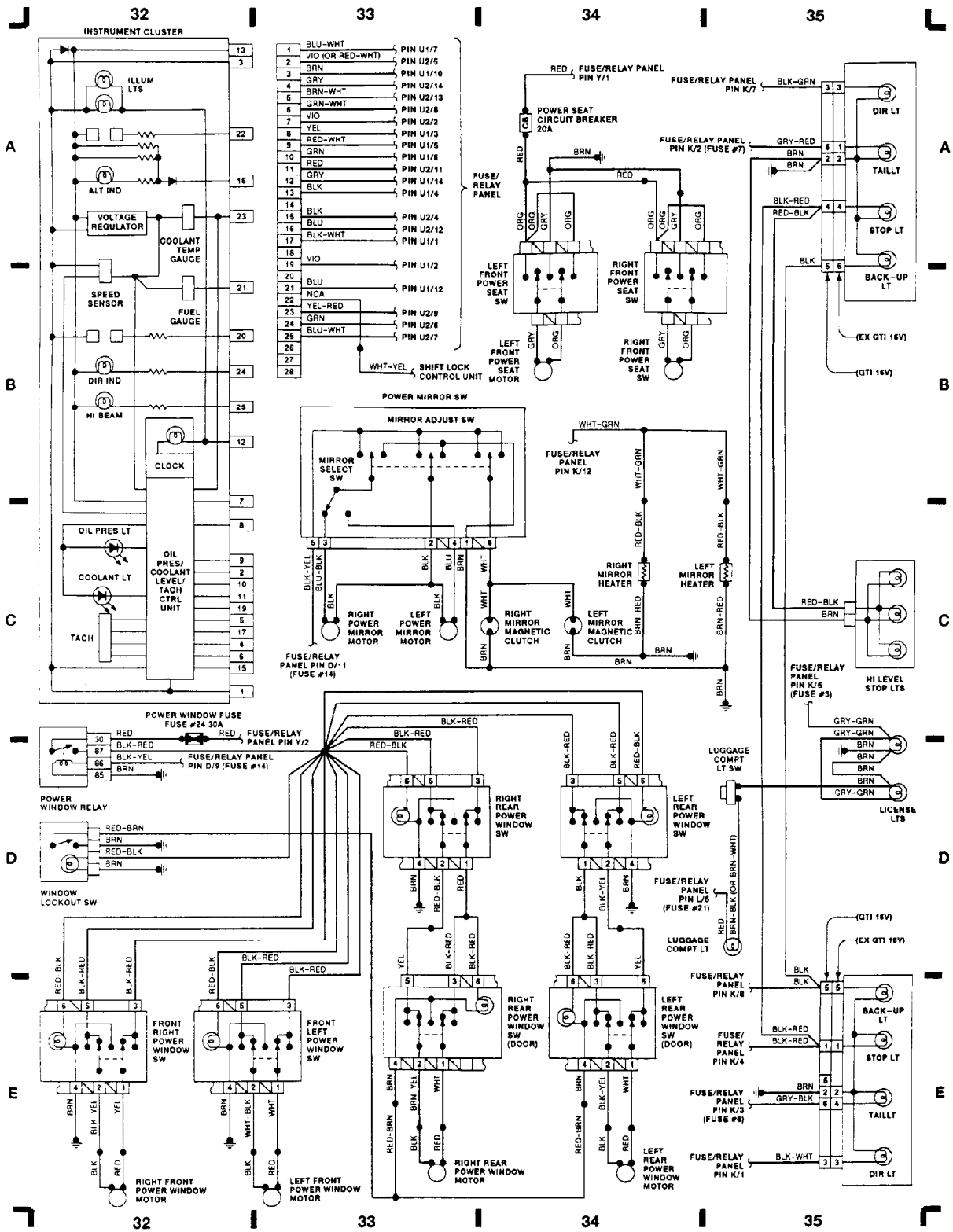

Fig. 9: Instrument Panel, Power Mirror Sw, (Grid 32-35)

50D01713