



Digitalis 1 1997-00

**Digifant I**

**Digifant II**

*Shop*

**ProTraining**

## DIGIFANT I

### System Components/Operation

System Description .....	1
Electronic Control Unit (E.C.U.) .....	3
Coolant Temperature Sensor .....	4
Fuel Pump .....	4
Air Flow Sensor .....	5
Intake Air Temperature Sensor .....	5
Fuel Pressure Regulator .....	6
Fuel Injectors .....	6
Throttle Switch .....	7
Fuel Filters .....	7
Oxygen Sensor .....	8
Ignition System .....	9
Idle Stabilization .....	10
Crankcase Emission Control/Vent-Line Heating Element .....	11
Evaporative Emission System .....	12

### Checking/Adjusting

Throttle Valve .....	13
Throttle Switch (Adjusting) .....	14
Throttle Switch (Wiring And E.C.U. Check) .....	16
Coolant Temperature Sensor .....	17
Air Flow Sensor/Intake Air Temperature Sensor .....	18
Fuel Injectors (Spray Pattern, Quantity) .....	19
Fuel Injectors (Leak Checking, Wiring Test) .....	20
Deceleration Fuel Cut-Off .....	22
Full Throttle Enrichment .....	23
Oxygen Sensor System .....	24
Fuel Pump (Pressure, Volume Test, Current Draw) .....	25
Fuel Pump (Electrical) .....	25
Fuel Pressure Regulator .....	27
Residual Fuel Pressure .....	27
Ignition System .....	28
Idle Stabilization System .....	30
Evaporative Emission System .....	34

### Basic Engine Adjustments

Ignition Timing, Idle Speed, CO Content .....	35
---	----

### System Check With Volt/Ohmmeter

System Test Chart .....	41
Functioning Wiring Diagram .....	42
Special Tools Required .....	44
Glossary/Component Location .....	45

# General Troubleshooting Guidelines

---

Fuel systems can be repaired by following the step-by-step procedures shown in this book.

## **Make Sure You Understand The Customer's Complaint**

- Identify the symptoms as you follow the diagnosis procedure. Try to determine the cause of the problem.
- Repair the problem after you have identified the symptoms.
- After completing repairs, always road test the vehicle before returning it to the customer.

## **Preliminary Checks**

A complaint may be caused by a minor detail. Before starting the fault finding procedure, make a few visual checks, such as:

- Are all electrical connections clean and tight? Spark plug wires not hanging loose, etc.
- Are all hoses OK? Check vacuum, crankcase ventilation, fuel tank ventilation, and air intake hoses for restrictions, cracks, or looseness.
- Are all the ground connections OK?
- Is there adequate fuel supply?

## **Pinpointing The Problem**

### **Remember the basics:**

- No matter how advanced the system, to start and run an engine you need correct spark timing, and the proper fuel-to-air ratio.
- Get as much information as possible from the customer.
- Gather as many symptoms as possible.
- Check the simple things first.
  - **Look** for spark.
  - **Listen** for the fuel pump.
  - **Feel** the injectors operating.
- **Make logical deductions, not assumptions.**

## **Intermittent Engine Performance Complaints**

Intermittent performance complaints can be caused by any part of the electrical, ignition, or fuel systems. Therefore, obtain as much information as possible from the customer. Find out under what conditions the problem occurs, how often, and for what duration. For example: engine cold?, during warm-up?, under load?, light acceleration?, highway driving?, only in hot weather?, only at high altitude? etc.... If possible, road test the vehicle to duplicate the condition.

When troubleshooting intermittent engine performance complaints:

- Pay very close attention to electrical connections on the fuel injection harness. Connectors which have insufficient tension, are bent, or show signs of corrosion **should be replaced and not repaired**.
- Corroded and/or loose ground connections should be cleaned and tightened.
- The complete fuel system should be checked, including the fuel quality.

# General Troubleshooting Guidelines

---

- **Engine will not start, hot or cold**

- a. No fuel
  - Page 25 Fuel System (Circuit Tests)
  - Page 20 Injectors (Circuit Tests)
  - Page 18 Air Flow Sensor
- b. No spark
  - Page 28 Ignition System

- **Hard starting, hot or cold**

- a. Insufficient or excessive fuel
  - Page 17 Coolant Temperature Sensor
  - Page 25 Fuel System
  - Page 27 Residual Pressure Test
  - Page 34 Evaporative Emission System
- b. Weak or no spark
  - Page 28 Ignition System

- **Poor idle**

- a. At operating temperature
  - Page 14 Throttle Switch
  - Page 30 Idle Stabilization System
  - Page 34 Evaporative Emission System
- b. Cold engine
  - Page 17 Coolant Temperature Sensor
  - Page 30 Idle Stabilization System

- **Engine stalls at highway speeds**

- a.
  - Page 25 Fuel System (Pressure, Volume, Current Draw)
  - Page 34 Evaporative Emission System
  - Page 35 Basic Engine Adjustments
  - Page 40 Ground and Terminal Connections

# General Troubleshooting Guidelines

---

## • Poor performance

### a. During warm-up

- Page 35 Basic Engine Adjustments
- Page 17 Coolant Temperature Sensor
- Page 14 Throttle Switch
- Page 30 Idle Stabilization System

### b. At operating temperature

- Page 35 Basic Engine Adjustments
- Page 14 Throttle Switch
- Page 24 Oxygen Sensor System
- Page 28 Ignition System
- Page 25 Fuel System (Pressure, Volume, Current Draw)
- Page 30 Idle Stabilization System

### c. At full throttle

- Page 23 Full Throttle Enrichment
- Page 28 Ignition System

## • High fuel consumption

- Page 24 Oxygen Sensor System
- Page 25 Fuel System (Pressure, Volume Tests)
- Page 19 Fuel Injectors (Spray Pattern, Leakage)
- Page 23 Full Throttle Enrichment
- Page 34 Evaporative Emission System (Leakage)

### **Note:**

Driveability problems that occur even when all engine specifications are in order may be caused by injector tip gum-up or carbon build-up on the intake valves and injector tips. These deposits are related to the use of gasoline with insufficient cleaning additives and can be prevented by:

- Using only major brand gasolines that advertise their additive packages are effective for cleaning fuel injection systems.
- Avoiding fuels that contain alcohol.
- Regular use of supplemental additives such as Autobahn Fuel Additive, which is

specially formulated to prevent carbon, gum or varnish build-up and help break down existing deposits.

Once formed, many deposits cannot be removed by normal preventative measures such as the use of fuel additives. Most injector deposits can be removed by using a special cleaning system like our G-16 Fuel Injection System Cleaner. Carbon build-up may require mechanical removal.

Check Group 24 of your Technical Information Book for further information on injection system cleaning and de-carbonization.

# System Components/Operation

## System Description

The 2.1 liter Vanagon engine is equipped with Digifant fuel and ignition control system. Digifant is a development of the Digi-Jet fuel injection system combined with the map controlled digital ignition system.

Through the use of a single control unit, all of the functions of the fuel system, ignition system and oxygen sensor system are carefully controlled to provide optimum mixture and ignition control for

improvements in acceleration, deceleration and overall driveability.

The Digifant system features a larger throttle bore diameter, increased from 45 mm to 50 mm.

An idle stabilization system has been incorporated to further streamline the system and eliminates the need for a digital idle stabilizer and auxiliary air regulator.

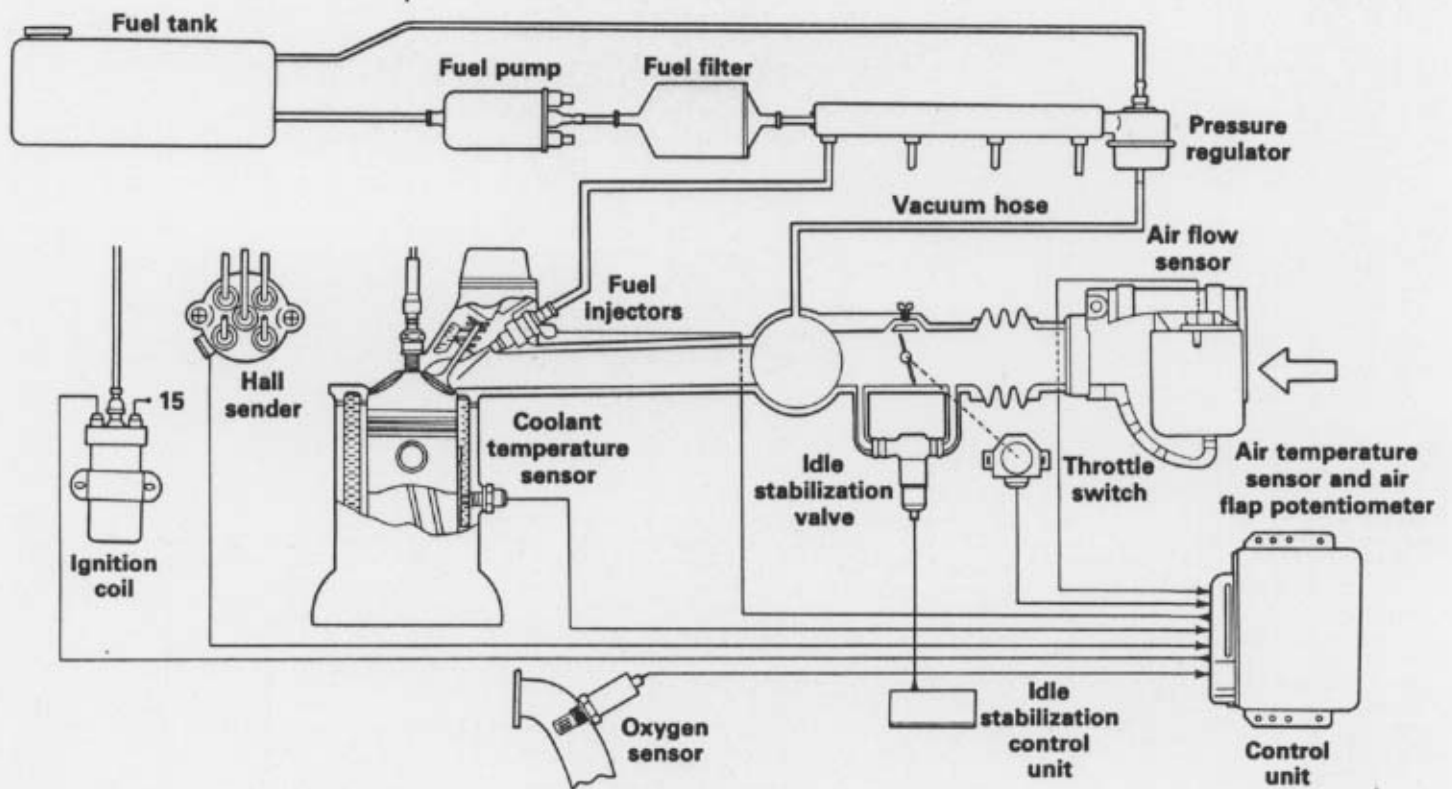

# System Components/Operation

The individual components of the Digifant system work together to manage all aspects of engine operation.

Fuel injection control is electronic and is based on the measurement of air entering the intake and on engine speed measured by the Hall sender. The coolant temperature sensor provides correction during engine starting and warm up.

The oxygen sensor, intake air temperature

sensor and throttle switch provide the control unit with additional information to assure smooth performance under all driving conditions. A separate control unit is used for the idle stabilization valve.

Ignition timing control is determined by an engine speed signal from the Hall sender, and a load signal from the air sensor. A signal from the coolant temperature sensor provides a correction factor.

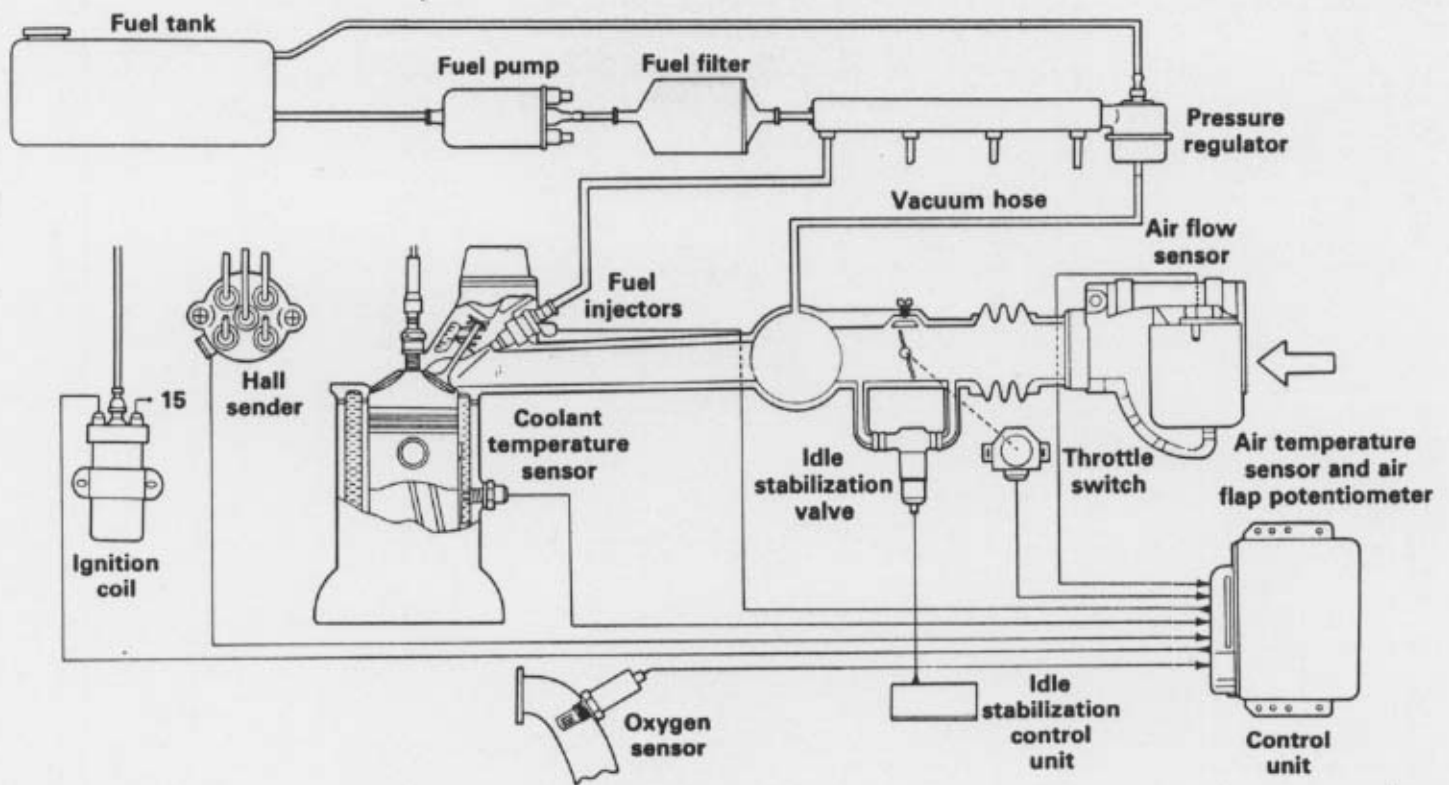

# System Components/Operation

## Electronic Control Unit (E.C.U.)

The Digifant electronic control unit incorporates all the functions of the fuel system and ignition system and provides both the actuation signal for the fuel injectors and optimum ignition timing point for all engine operating conditions.

Injection duration opening signals are provided based on the following inputs:

- Engine speed
- Intake air volume
- Coolant temperature
- Oxygen content in the exhaust gas

- Battery voltage
- Throttle position
- Intake air temperature

The injector opening time is taken from a program in the control unit at 16 points for RPM and 16 points for load for a total of 256 operational points. Injection times can be determined between these fixed points for a total of 65,000 theoretical different opening duration points.

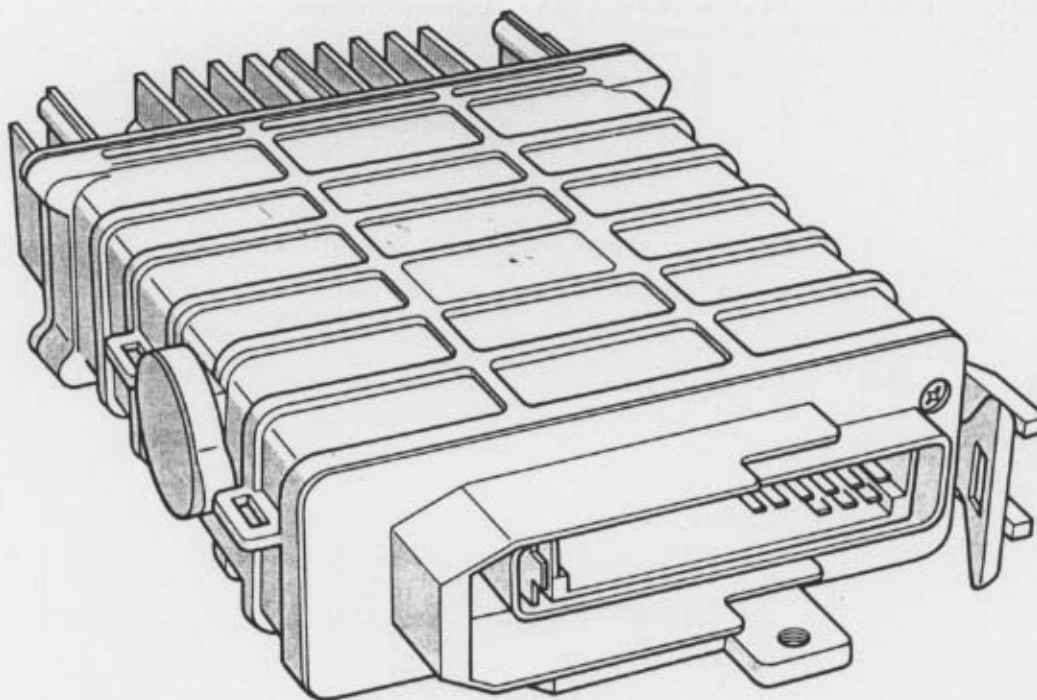



# System Components/Operation

## Fuel Pump/Power Supply Relays

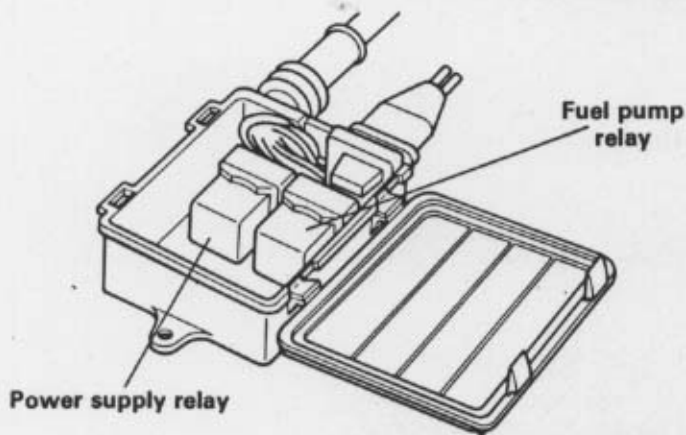

When energized by the ignition switch and grounded by the Digifant E.C.U., the fuel pump relay provides battery voltage to the fuel pump, injectors, idle stabilization control unit, oxygen sensor heating element and the power steering pressure switch.

When energized by the ignition switch, the power supply relay provides battery voltage to the Digifant E.C.U.

## Coolant Temperature Sensor

The coolant temperature sensor is a negative temperature coefficient resistor (NTC). The

resistance signal it produces is used by the control unit to determine:

- The amount of cold start and warm-up enrichment
- Ignition timing and idle stabilization during warm-up
- When the oxygen sensor, idle stabilization, and full throttle enrichment functions are activated

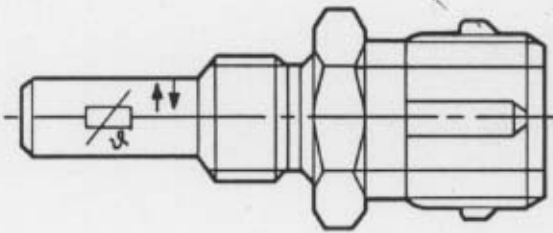

## Fuel Pump

The fuel pump is a roller cell design. It is driven by a permanent magnet electric motor and is located near the fuel tank.

Steel rollers are held in "cut-outs" on the rotor. Centrifugal force seals the rollers against the walls of the pressure chamber as the rotor spins. Fuel that is trapped between the rollers is forced out the delivery port. The pump is designed to be both cooled and lubricated by the fuel flowing through it.

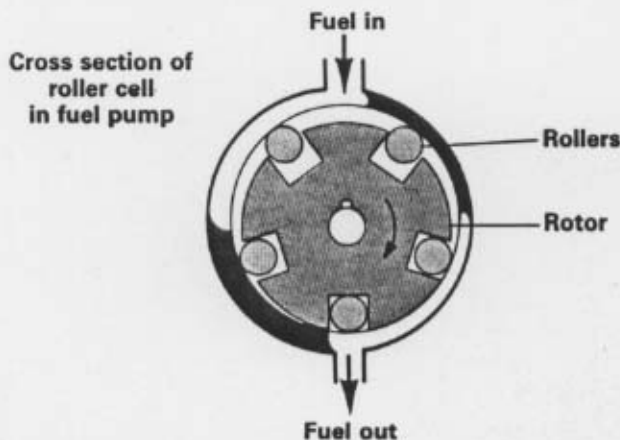

The pump delivers several times the amount of fuel needed to operate the engine at any time. Excess fuel is returned to the fuel tank via the fuel pressure regulator.

# System Components/Operation

## Air Flow Sensor

The air flow sensor measures the amount of air entering the intake manifold and sends a voltage signal to the control unit.

Intake air opens the air flow sensor flap which actuates the potentiometer to determine the voltage signal. This signal and the engine speed information supplied by the Hall sender are used as the principal inputs for the determination of fuel injector opening duration and ignition timing points.

A compensation flap connected to the air sensor dampens sudden movements of the air sensor flap due to oscillations of the intake air.

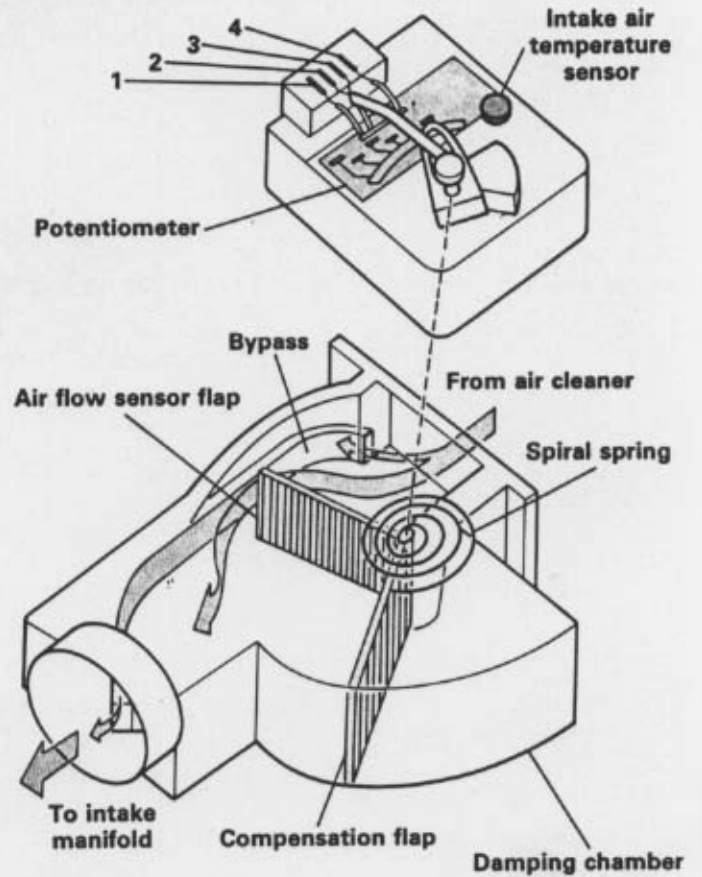

## Intake Air Temperature Sensor

An intake air temperature sensor is mounted in the air flow sensor housing. It is a negative temperature coefficient (NTC) resistor, which means its resistance value drops as its temperature increases. The signal it supplies to the control unit is used to modify fuel injection rate depending on intake air temperature. The sensor can be tested by measuring the resistance value of the sensor and comparing the reading to a graph.

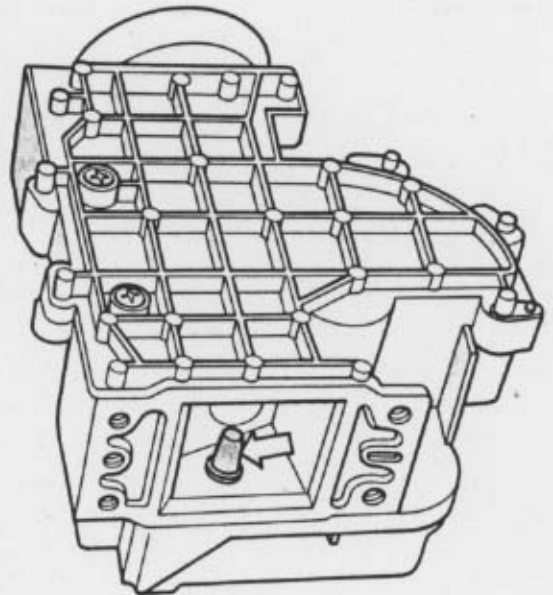

# System Components/Operation

## Fuel Pressure Regulator

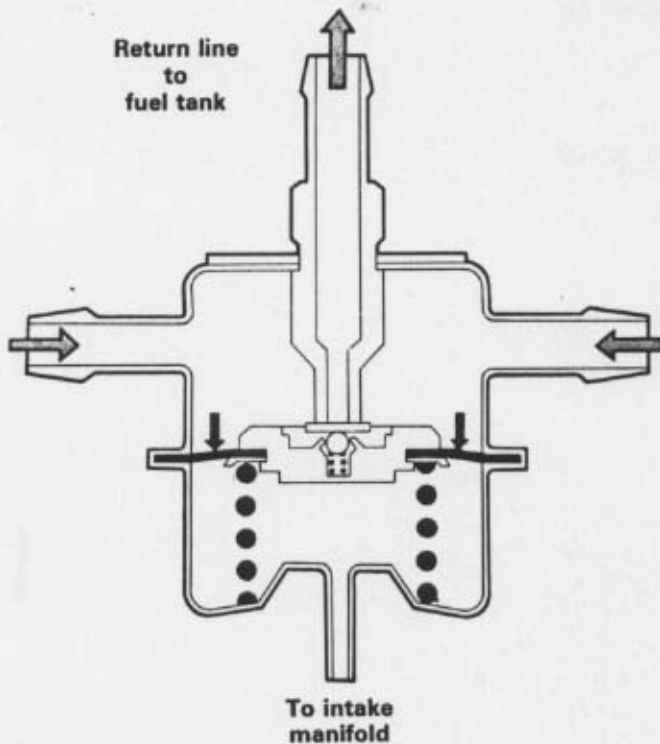

The system pressure regulator maintains a constant fuel pressure to all injectors by regulating the quantity of fuel returned to the fuel tank.

The regulator is connected to the intake manifold. It responds to manifold vacuum fluctuations, and thereby compensates for engine-load changes.

When the engine is shut off, the regulator closes and seals to maintain residual fuel pressure in the injector lines for improved hot-start capability.

## Fuel Injectors

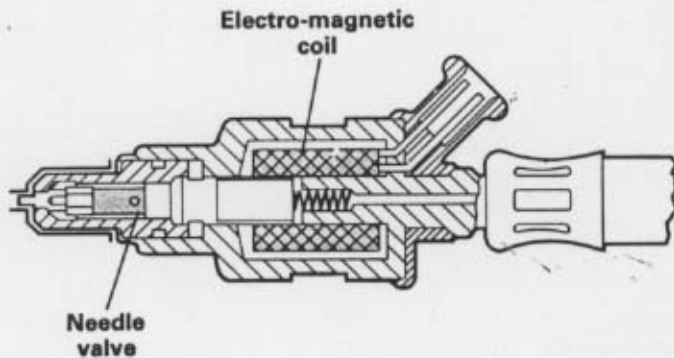

Digital fuel injectors are electronically controlled on/off valves. A solenoid actuates a needle valve allowing fuel to be forced through the injector nozzle. All four injectors open at the same time and inject fuel directly into the intake manifold near the intake valve. Injection quantity is controlled by the amount of time the injectors stay open. Injector opening time is regulated by the E.C.U., based on inputs from the various engine sensors.

**Note:** Digital injectors (yellow body) are not interchangeable with A.F.C. injectors (blue body).

## Throttle Switch

Digifant uses a single throttle switch to signal the E.C.U. when the throttle plate is in the fully closed (idle) or fully open (full load) position. The signal enables the E.C.U. to determine that one of three auxiliary functions (idle stabilization, deceleration fuel shut-off, or full load enrichment) is required and activates the appropriate circuit.

The throttle switch is an NOC switch, or **normally open unless** actuated. The contact arm is actuated by a cam with two eccentrics which attaches to the throttle plate shaft. One eccentric closes the contacts in the fully closed (idle stabilization or decel fuel shut-off) position, and the other in the fully open (full load enrichment) position.

Correct adjustment of the throttle switch is very important. If the switch is misadjusted, the engine may surge at idle or cut out during steady driving or light acceleration.

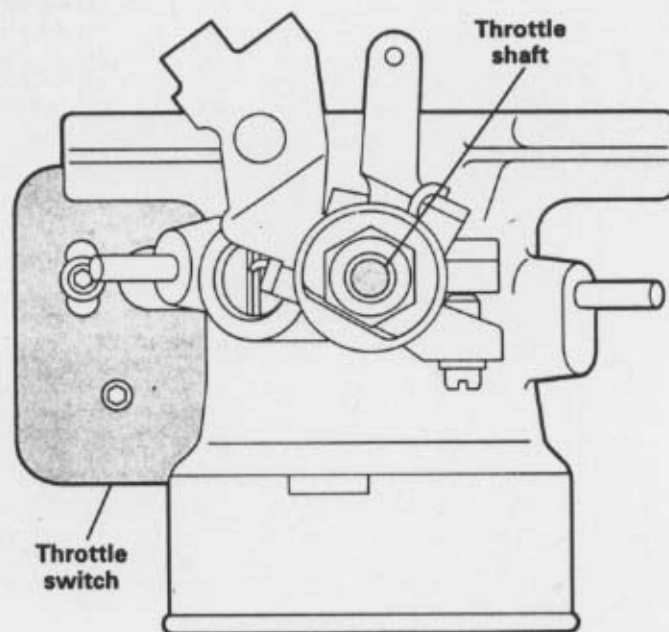

## Fuel Filter

The fuel filter is a metal cylinder that mounts behind the fuel pump.

It has an extremely fine filtering mesh to protect the fuel injection components.

The fuel filter is a lifetime filter and does not require replacement under normal circumstances.

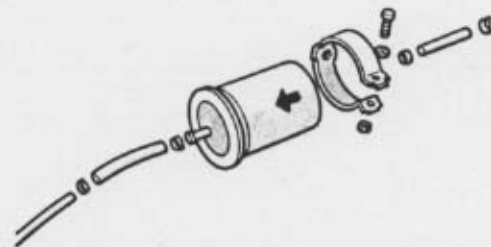

# System Components/Operation

## Oxygen Sensor

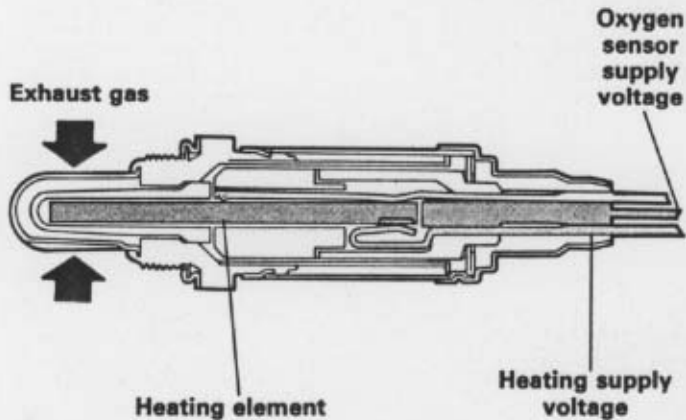

The oxygen sensor is made of a ceramic material called Zirconium dioxide. The inner and outer surfaces of the ceramic material are coated with platinum. The outer platinum surface is exposed to the exhaust gas, while the inner surface is exposed to the outside air.

The difference in the amount of oxygen contacting the inner and outer surfaces of the oxygen sensor creates a pressure differential which results in a small voltage signal in the range of 175 to 1100 (0.175-1.1V) mV being supplied to the E.C.U. The amount of voltage that is produced is determined by the fuel mixture. A high voltage signal indicates a rich mixture, and a low voltage signal indicates a lean mixture.

The oxygen sensor is heated electrically to keep it at a constant operating temperature. This insures continuous and accurate reaction of the sensor during all operating conditions.

The heated oxygen sensor has three wires, two for the heating element (ground and power) and a signal wire for the oxygen sensor. Power is supplied to the heating element whenever the ignition is on.

The oxygen sensor has a 90,000 mile replacement interval. A mileage counter will activate a warning light on the dash at 90,000 miles. At this time, the oxygen sensor should be replaced and the mileage counter reset.

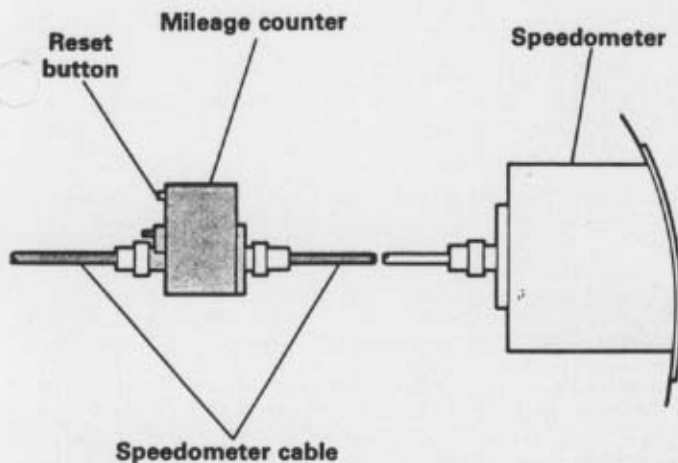

## Ignition System

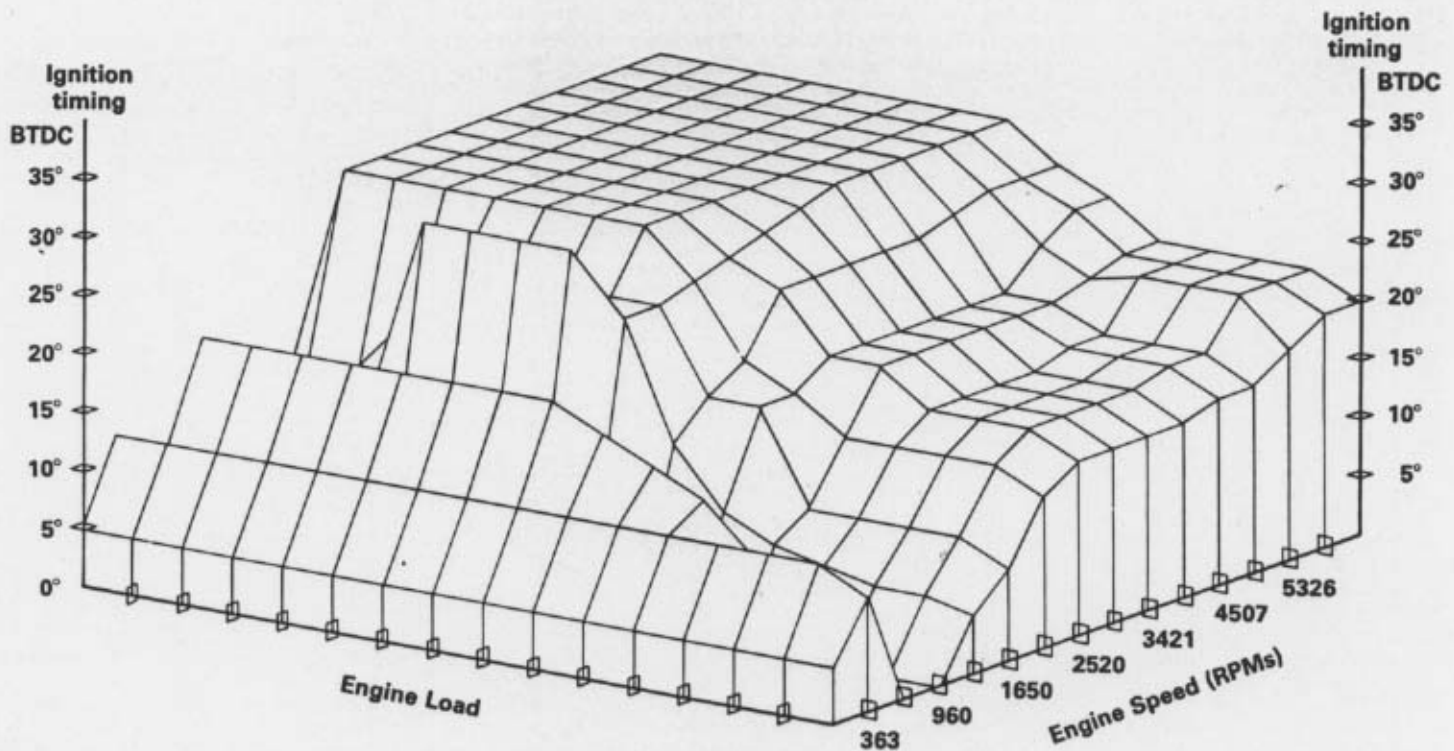

The ignition system operates on the principle of a timing map programmed into the E.C.U. Information on engine load, speed and coolant temperature are provided to the E.C.U. in the form of voltage signals. In the E.C.U., these signals are processed so that the ignition coil is controlled via terminal 1 in accordance with the programmed ignition map. The separate ignition control unit and digital idle stabilizer used in the past have been eliminated.

An engine speed signal comes from the Hall sender in the distributor. Measurement of engine load is accomplished through a signal from the air sensor potentiometer. These two

signals establish the ignition timing point. They are stored in the ignition map in the control unit's memory as 256 single operational points, 16 fixed points for each engine load point and 16 for each RPM point.

The engine coolant temperature sensor signals the control unit to determine ignition timing based on engine temperature. Throughout the engine warm-up phase, ignition timing is constantly being corrected.

Once the engine reaches operating temperature, the timing is determined by the map shown.

# System Components/Operation

## Idle Stabilization

The idle stabilization system used on the Digifant system insures that the idle speed remains constant at predetermined levels. The system controls the amount of air bypassing the throttle plate.

If engine idle speed varies from the value stored in the control unit, the idle stabilizer valve will adjust the volume of air entering the engine at idle. This maintains idle speed within certain limits.

The idle stabilizer valve is operated by a control unit located in front of the right hand taillight assembly.

The control unit receives inputs from the following components:

- Throttle switch
- Coolant temperature sensor
- A/C compressor clutch
- Ignition coil terminal #1
- Power steering pressure switch

With this system, the auxiliary air regulator and digital idle stabilizer are eliminated and any periodic idle adjustment is no longer required.

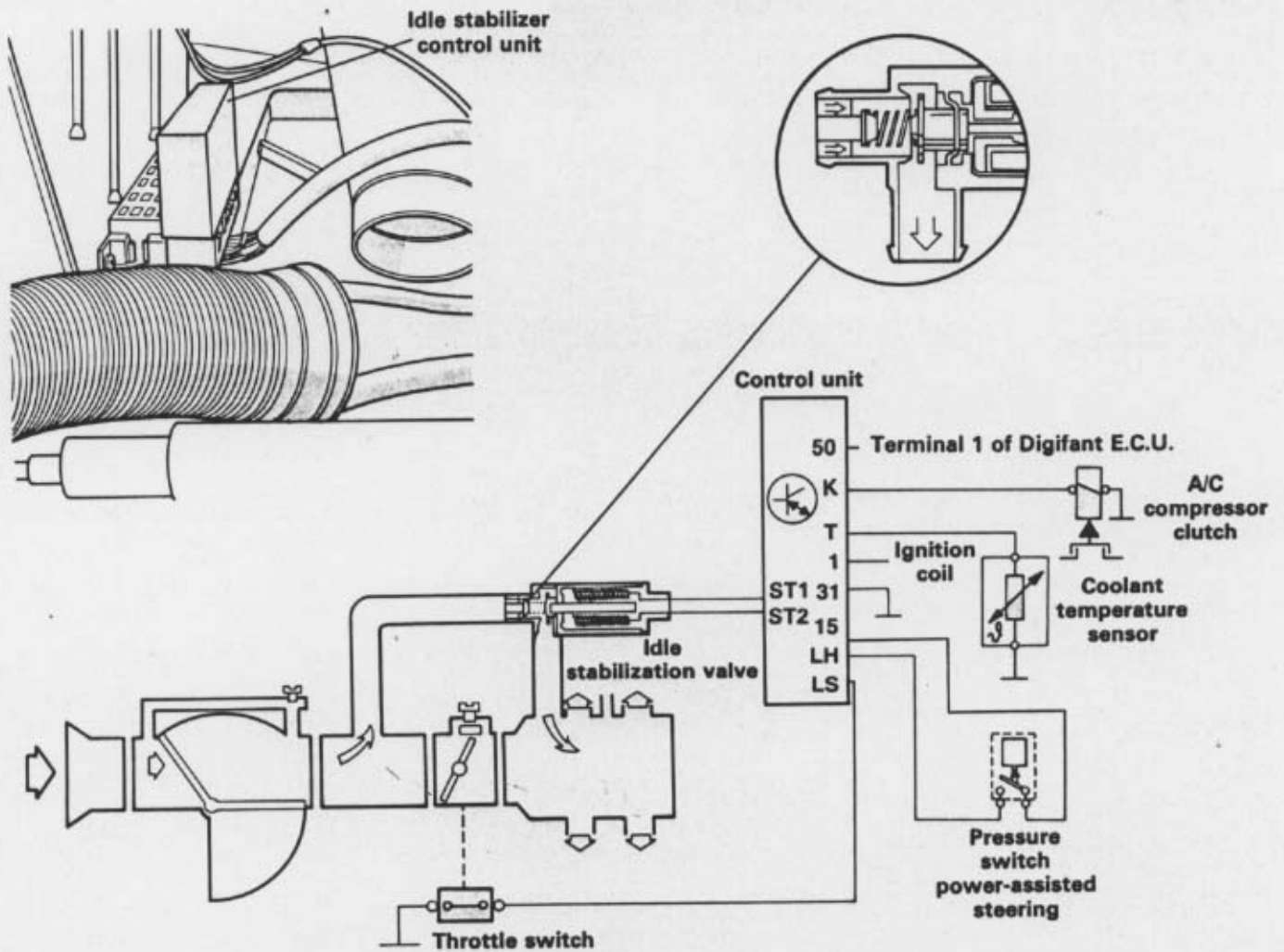

# System Components/Operation

## Crankcase Emission Control

The crankcase emission control system is a closed system. No crankcase emissions are discharged into the atmosphere.

The control valve allows crankcase emissions to enter the intake air boot any time the engine is running to help control crankcase pressure.

The crankcase vapors vent to atmosphere during adjustment.

When checking or adjusting CO content, the hose from the crankcase emission control valve is disconnected and plugged.

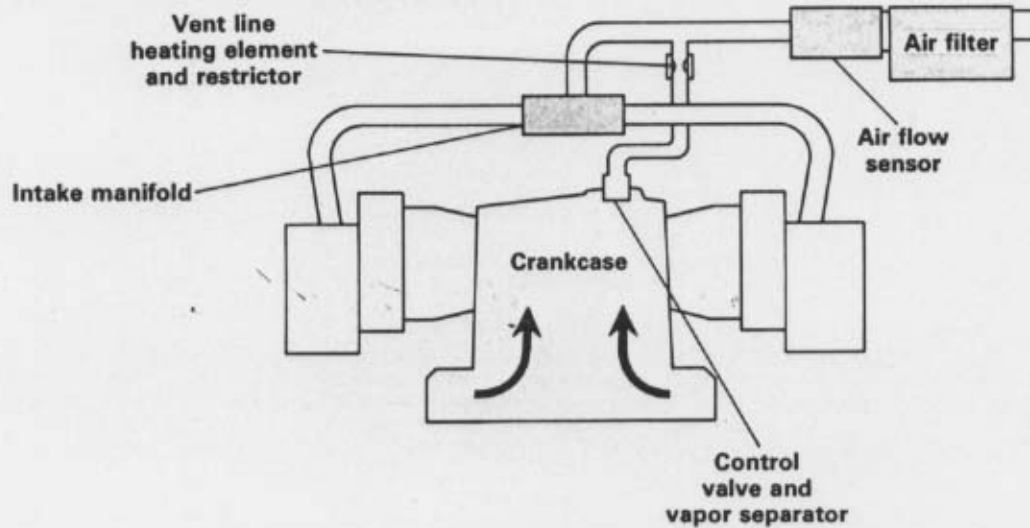

## Vent Line Heating Element

A heating element is used in the crankcase vent line to prevent icing during cold engine operation. This element has a 5.5 mm hole in the restrictor plate. The element can be checked with an ohmmeter. Resistance should be between 4 ohms and 17 ohms at 25°C (77°F).

The circuitry to operate the heating element is protected by an in-line, 5 amp fuse (SAE type) located in the wiring connector box in the engine compartment.

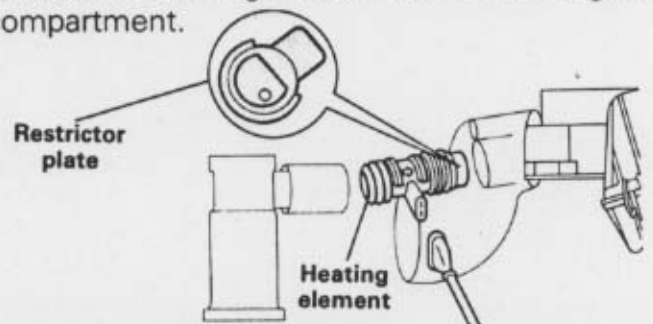
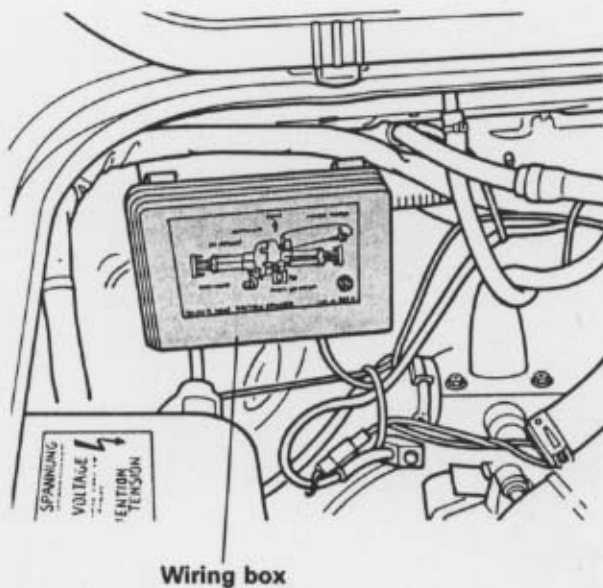



# System Components/Operation

## Evaporative Emission System

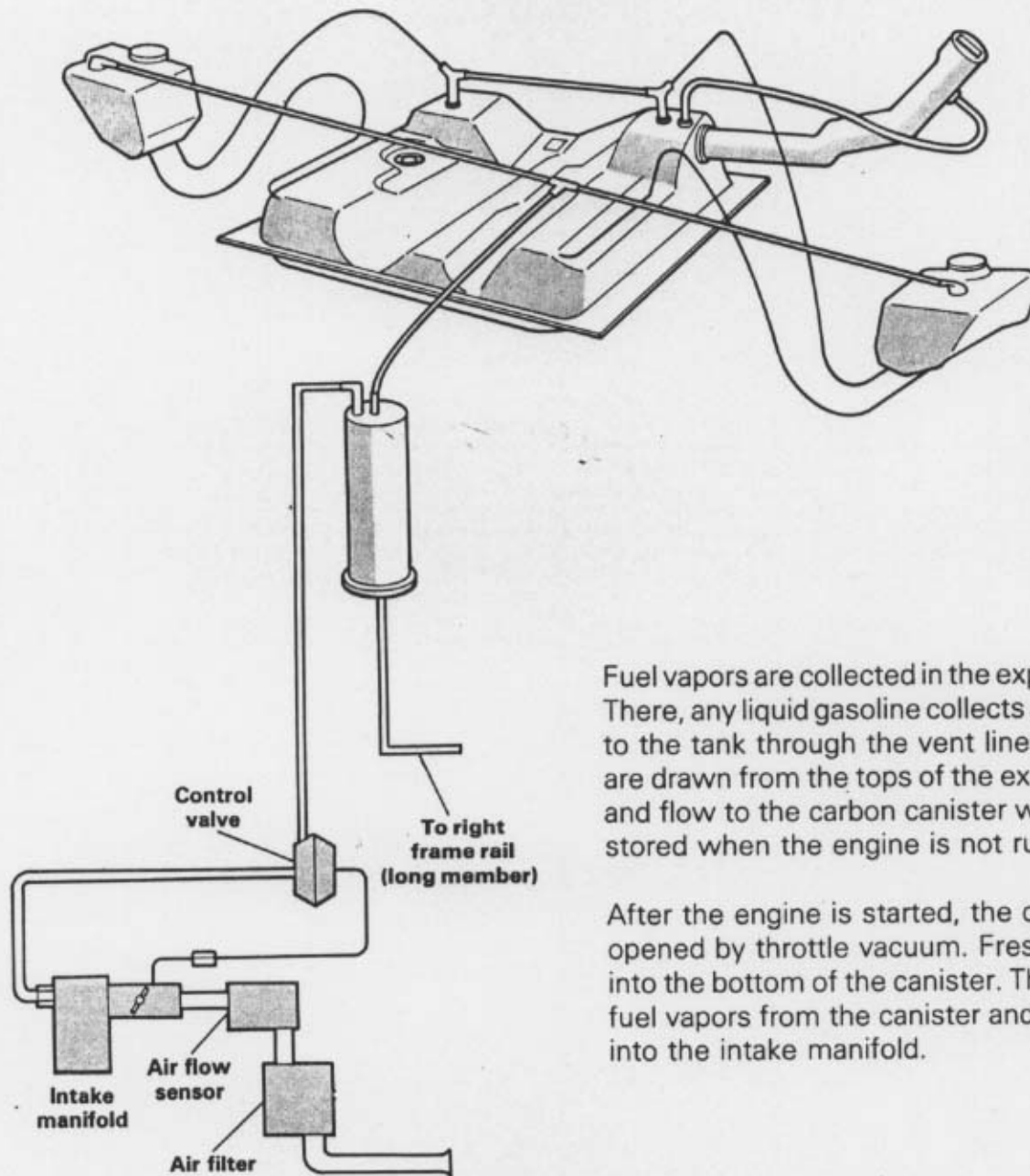

Engine Compartment

Fuel vapors are collected in the expansion tanks. There, any liquid gasoline collects and flows back to the tank through the vent lines. Fuel vapors are drawn from the tops of the expansion tanks and flow to the carbon canister where they are stored when the engine is not running.

After the engine is started, the control valve is opened by throttle vacuum. Fresh air is drawn into the bottom of the canister. There it collects fuel vapors from the canister and is then drawn into the intake manifold.

## Throttle Valve - Basic Adjustment

**Note:**

The stop screw is set at the factory and should not be moved. If the screw position has been altered, check basic adjustment as follows:

- Remove purple vacuum line from purge control fitting of the throttle valve. (1)
- Install vacuum pump US 8026 or equivalent to fitting.
- Start engine and let idle.
  - At idle, vacuum should be 0 in. Hg (up to 1 in. Hg is acceptable)

If there is 1 in. Hg or more vacuum, or if the tamper proof paint on the throttle stop screw is broken, adjust the throttle valve as follows:

- Turn the throttle stop screw (2) **out** until a gap exists between the screw and the stop.
- Place a piece of paper between the screw and the stop.
- Turn the screw **in** until you feel a very slight drag on the paper.
- Turn the stop screw **in** an additional 1/2 turn.
- Repeat the vacuum test at the purge fitting.

If OK,

- Reapply paint to the stop screw.
- Check idle speed and CO content.
- Adjust, if necessary.

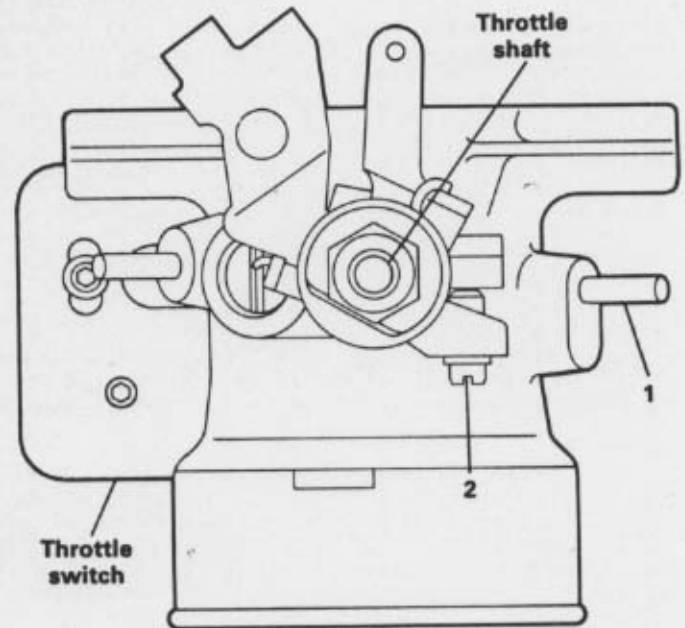

# Checking/Adjusting

## Throttle Switch — Checking And Adjusting

### Note:

If the throttle valve switch is misadjusted, the engine may surge at idle or cut out during steady driving or light throttle application.

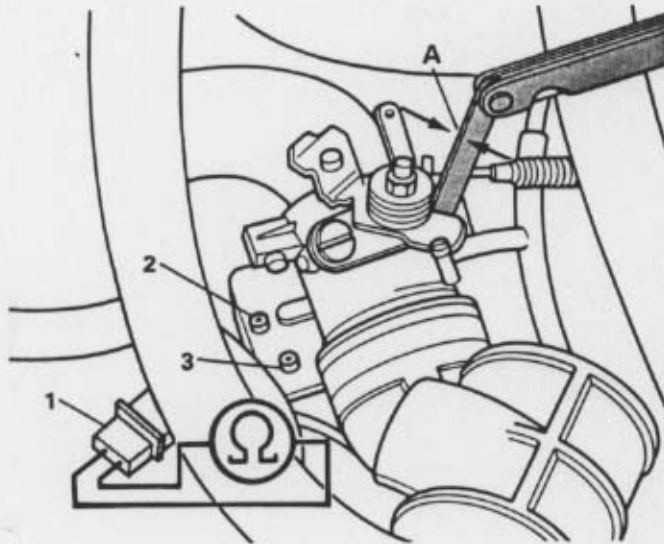

### Checking:

- Check that the throttle stop screw is adjusted properly (see page 13).
- Disconnect throttle switch connector.
- Connect US 1119 multimeter between male terminals of throttle switch connector plug (1). Set meter to 200 ohm scale.
  - When the throttle valve is closed (idle), meter must read 0.0 ohms. (Continuity through switch)

If **not OK**, switch must be replaced or adjusted so it is closed at idle.

- Open throttle valve far enough to open throttle valve switch.
  - Multimeter must read ∞ ohms. (OL on US 1119)
- Insert a 0.05 mm (0.002 in) feeler gauge between the stop screw and stop (A) and let throttle valve close completely.
  - The throttle valve switch must **close** (multimeter reads 0.0 ohms).
- Open throttle valve and insert a 0.10 mm (0.004 in) feeler gauge and let throttle valve close completely.
  - The throttle valve switch must **remain open** (multimeter reads ∞ ohms, OL on US 1119).

If **not OK**,

- Adjust the switch as follows:

## Throttle Switch — Checking And Adjusting (Cont'd.)

**Note:**

Excessive throttle shaft wear can cause the idle speed to increase when the A/C is on. It can also cause the engine to buck or jerk during light throttle.

If the throttle switch can be activated by moving the shaft forward and backward or side to side, the throttle housing will need to be replaced.

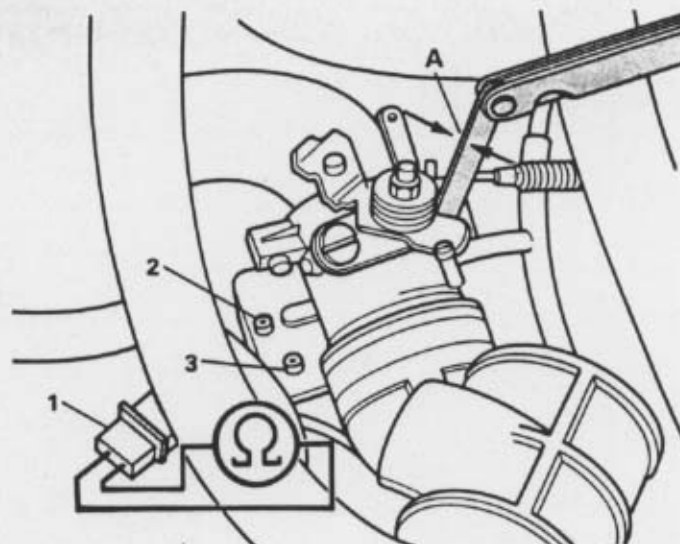
**Adjusting:**

**Do not** use the throttle valve stop screw for adjusting the throttle switch.

- Loosen screw 2.
- Insert 0.07 mm feeler gauge between throttle stop screw and throttle stop A.
  - The closing point of the throttle switch is:  
0.05 - 1.0 mm  
(0.002 - 0.004 in)
- Adjust the throttle switch so it closes at 0.07 mm by using screw 3.
  - Ohmmeter should read 0.0 ohm.
- Tighten screw 2.
- Verify the adjustment by opening and closing the throttle valve.
  - Ohmmeter should read 0.0 ohm with a 0.07 mm feeler gauge installed.

**If not OK,**

- Repeat adjustment and re-check.
- Check the operation of the throttle valve switches **USING THE ACCELERATOR PEDAL** as follows:

# Checking/Adjusting

## Throttle Switch — Checking And Adjusting (Cont'd.)

- Press the accelerator pedal fully to the floor.
  - Ohmmeter must read 0.0 ohms.
- Check that the throttle switch closes when the accelerator cable is released.

If **not OK**, either the accelerator cable needs adjustment or there is a problem with the throttle switch actuating cam.

- Press the accelerator pedal from idle to full throttle position.
  - Ohmmeter must read 0.0 ohm at idle.
  - Ohmmeter must read  $\infty$  ohm (OL on US

1119) when accelerator pedal is between idle and full throttle positions.

If **not OK**, there may be a problem with either the throttle switch, the actuating cam, or with excessive play between the throttle shaft and throttle housing.

## Wiring And E.C.U. Check

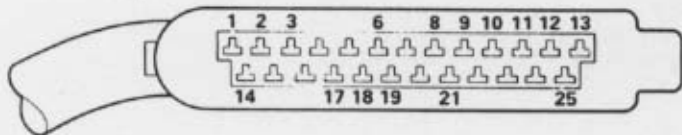
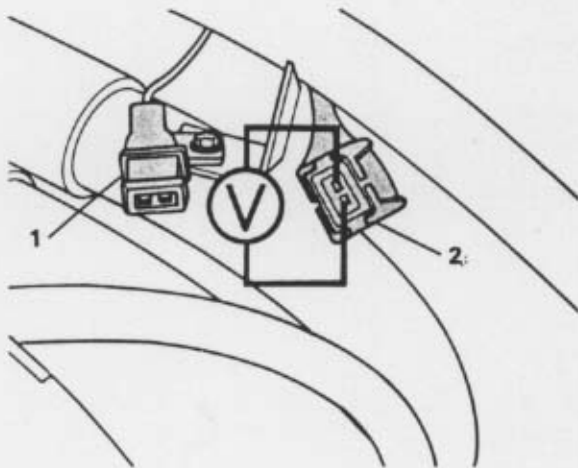

- Coolant temperature above 60°C (140°F)
- Switch ignition ON
- Disconnect throttle switch connector.
- Measure voltage between the two female terminal ends of the wiring from the E.C.U. (1).
  - Approximately 5.0 Volts

### Note:

Do not use a test light to check for voltage or throttle switch operation or the E.C.U. will be damaged.

If voltage is **OK**,

- Replace Digifant E.C.U. and re-test.

If voltage is **not OK**,

- Check wiring to terminals 6 and 11 of Digifant E.C.U. and repair as necessary.

# Checking/Adjusting

## Coolant Temperature Sensor — Checking

The following checks verify proper function of the coolant temperature sensor, related wiring and connectors.

- Switch ignition OFF
- Disconnect multi-pin connector from E.C.U.
- Measure temperature of coolant temperature sensor with probe type thermometer.
- Connect ohmmeter to terminals 6 and 10 of E.C.U. plug.
  - Resistance should correspond with graph.

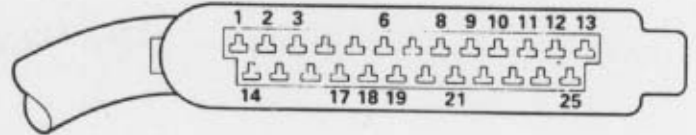

If resistance is not within specifications:

- Disconnect coolant temperature sensor (Do not let connector touch exhaust manifold).
- Bridge terminals of coolant temperature sensor with ohmmeter.
  - Resistance should correspond with graph.

If **not OK**,

- Replace sensor.

If resistance value is **OK**,

- Check wiring to E.C.U.

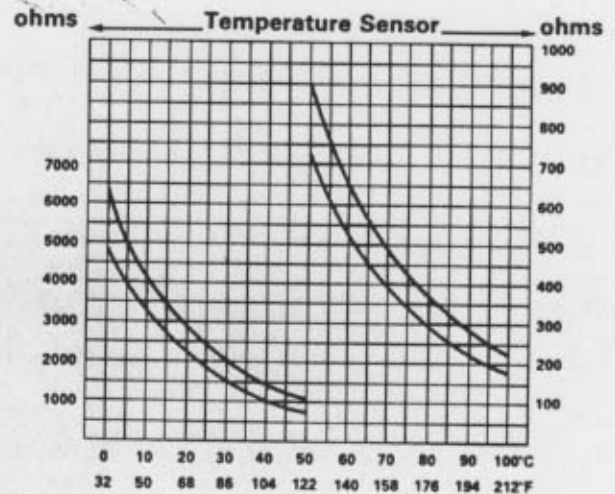

# Checking/Adjusting

## Air Flow Sensor/Intake Air Temperature Sensor — Checking

### Wiring And Component Checking

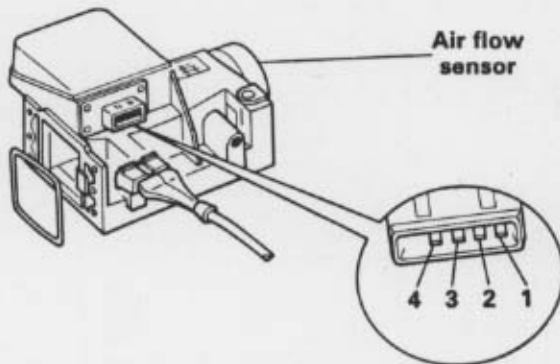
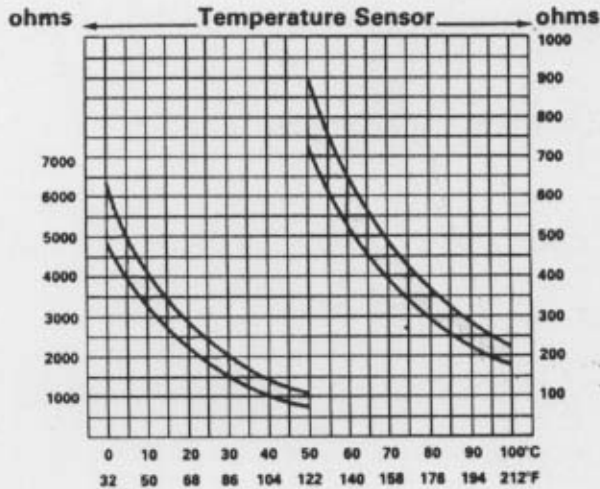
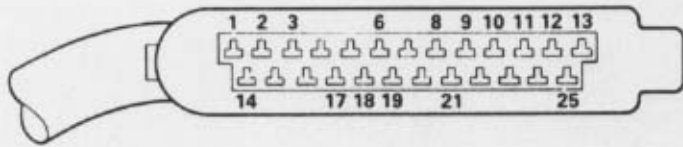

The following tests are to verify proper function of the air flow sensor, related wiring and connectors.

- Switch ignition OFF.
- Disconnect multi-pin connector from Digifant E.C.U.
- Connect ohmmeter to terminals of multi-pin connector to test wiring through air flow sensor.  
(See column "A" for terminal numbers.)

If readings do **not** meet specifications:

- Disconnect connector at air flow sensor.
- Connect ohmmeter to terminals shown in column "B" to connector pins of air flow sensor.

If readings meet specifications:

- Check wiring.

If readings do **not** meet specifications:

- Replace air flow sensor and re-test.

Column "A" Connections at E.C.U. Multi-pin Connector	Column "B" Connections at Air Flow Sensor	Description	Specification
Terminal Nos. 6 and 17	Terminal Nos. 3 and 4	Potentiometer - Total Resistance	500 to 1000 Ohms
17 and 21	2 and 3	Potentiometer - Resistance Measured Through Wiper Arm	Ohms Fluctuate As Sensor Flap Is Opened (Flap Must Move Freely)
6 and 9	1 and 4	Intake Air Temperature Sensor	Ohmmeter Reading Corresponds to Graph

## Fuel Injectors — Checking

### Spray Pattern/Delivery Quantity

- Remove fuel injectors in pairs (left or right).
- Disconnect the electrical plugs from the fuel injectors.
- Place the injector to be tested in a graduated container.
- Connect self-made jumper harness (see Special Tools in Digifant II section for details).
- Connect one lead to terminal 15 of the ignition coil and the other lead to ground.
- Remove the fuel pump relay and install US 4480/3 in its place.
- Switch the ignition **ON**.

Switch US 4480/3 **ON** for exactly 30 seconds and observe injector spray pattern.

- Spray pattern must be even and cone-shaped.
- Delivery quantity for each injector must be a minimum of 87 cc after 30 seconds.
- Difference between high and low injection quantities must not exceed 9 cc.

If any of the specifications are **not** met:

- Check fuel pump pressure and delivery rate if delivery quantity is low for all injectors.
- Clean fuel injection system using Volkswagen solvent G 001 600.00 with adapter kit USG16.

**Note:**

Use new sealing rings when re-installing fuel injectors.

**WARNING**

Fire hazard. Do not smoke or have anything in the area that can ignite fuel when working on the fuel system.

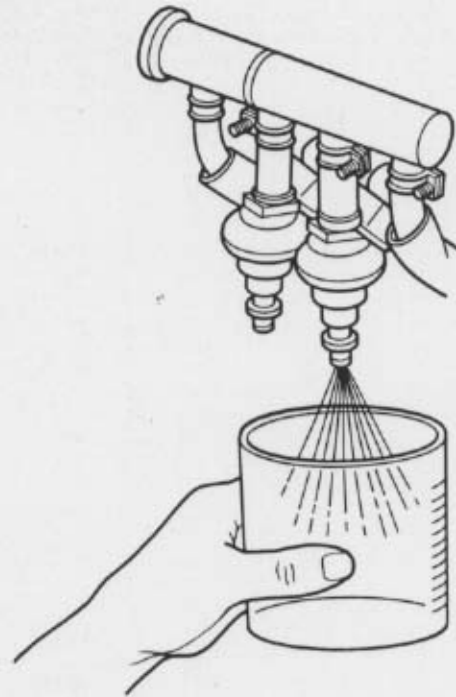



# Checking/Adjusting

## Fuel Injectors — Checking (Cont.) Leak Checking

- Remove electrical plugs at fuel injectors.

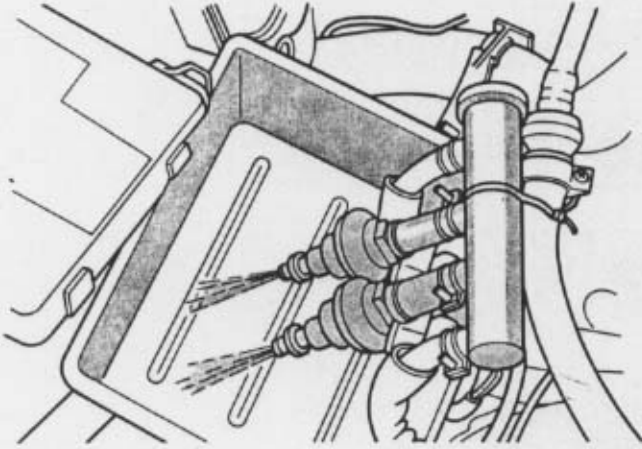

- Remove injectors in pairs but leave connected to fuel ring line.
- Switch ignition ON for about 5 seconds (fuel pump operates briefly).
- Check that no more than 2 drops leak from each injector in one minute.

### WARNING

Fire hazard. Do not smoke or have anything in the area that can ignite fuel when working on the fuel system.

## Component Tests

- Remove electrical plugs at fuel injectors.
- Connect ohmmeter across injector terminals.

- Reading should be approximately 16 ohms (14-18 ohms).

## Wiring Test

- Hall sender OK (Ignition coil produces spark while cranking).

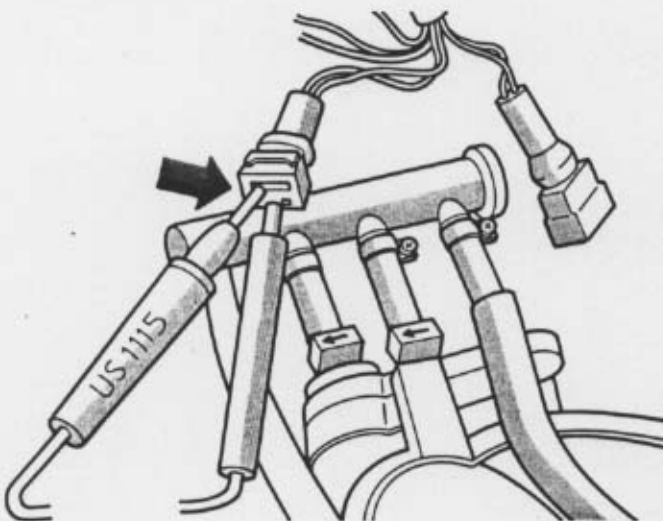

- Voltage supply from terminal 87 of fuel pump relay OK.
- Disconnect all electrical plugs from fuel injectors.
- Bridge contacts of one plug with US 1115 L.E.D. tester (or equivalent).
- Operate starter briefly (the diode must flicker) and repeat procedure on remaining plug contacts.

**Note:** If diode does not flicker, reverse test leads and repeat procedure to insure correct polarity of tester connections.

If **not OK**,

- Switch the ignition OFF.
- Remove the connector from the Digifant E.C.U.
- Reconnect the electrical connectors to the fuel injectors.

## Fuel Injectors — Checking Wiring Test (Cont'd.)

To check total resistance of all 4 injectors including wiring to the E.C.U. and fuel pump relay:

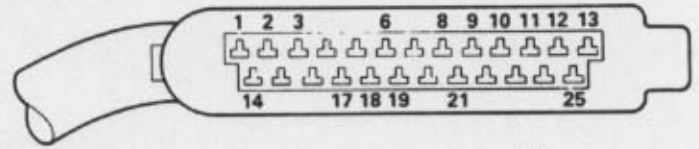

— Connect US 1119 to terminal 12 of the E.C.U. connector and to terminal 87 of the fuel pump relay and set to 200 ohm scale.

- Resistance should be approximately 3 - 5 ohms.

If **not OK**,

— Repair wiring using wiring diagram.

If resistance is **OK**,

— Replace E.C.U. and re-test.

# Checking/Adjusting

## Deceleration Fuel Cut-off — Checking

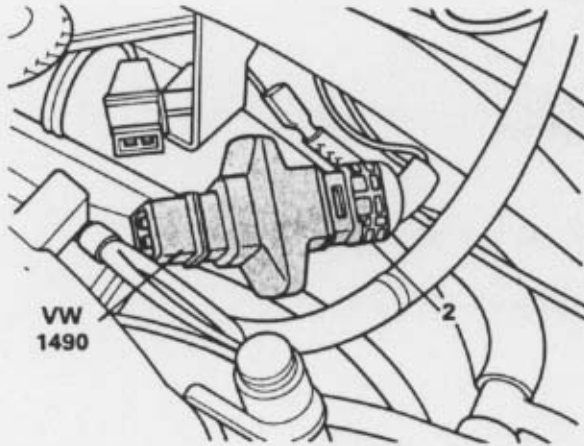

Coolant temperature must be at least 60°C (140°F) and resistance of temperature sensor 550 ohms or less.

- Start engine, raise engine speed above 3000 RPM once, then let idle.
- Disconnect throttle switch connector (2).
- Bridge the two female terminals of the throttle switch connector together using the bridge (—) end of tool VW 1490.
- Slowly increase engine speed.
  - At 2100 - 2500 RPM, injectors will be cut off and RPM will drop.
  - At 1300 - 1800 RPM, injectors will re-activate and RPM will rise.

This cycle will repeat as long as you attempt to hold a steady 2500 RPM.

If **not**,

- Check E.C.U. and wiring according to page 16.

## Full Throttle Enrichment — Checking

Coolant temperature must be at least 60° C (140° F) and resistance of temperature sensor 550 ohms or less.

- Connect CO tester, VW 1367 with VW 1473.
- Start engine and let idle for approx. 2 minutes.
- Disconnect throttle switch connector (2).
- Slowly increase engine speed to at least 4500 RPM.
  - CO must read 0.3 to 1.1% (note reading).
- While still maintaining at least 4500 RPM, bridge the two female terminals of the throttle switch connector together, using the (—) end of tool VW 1490.
  - Within a few seconds, CO reading must increase in volume by approximately 1% (or more).

If not,

- Check E.C.U. and wiring according to page 16.

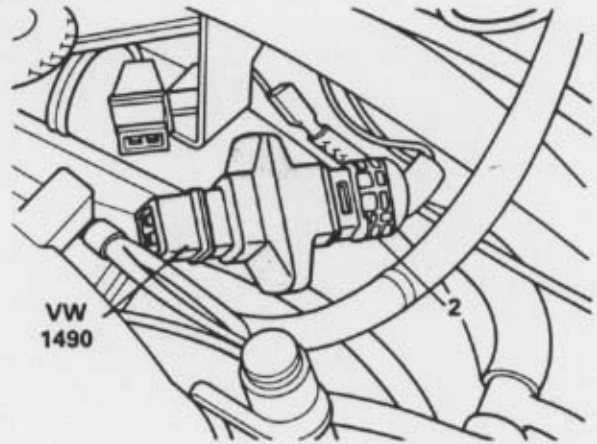

# Checking/Adjusting

## Oxygen Sensor — Checking

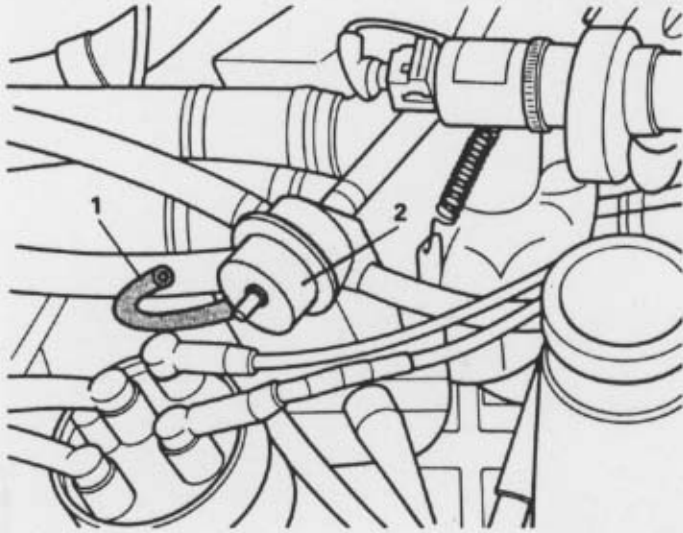

- Fuel pressure regulator **OK**.
- Engine at operating temperature.
- Oxygen sensor connected.
- Start engine and run for 2 minutes.
- Remove hose (1) from pressure regulator (2) and plug hose end.
  - CO value should increase briefly, then drop in value to 0.3 - 1.0%.

### If not **OK**,

- Shut engine OFF.
- Disconnect oxygen sensor.

### **Note:**

The oxygen sensor must be disconnected with the ignition off to cancel the Digifant E.C.U. memory.

- Start engine.
- Hold disconnected oxygen sensor wire from E.C.U. to ground.
  - CO content must rise.

### If CO content rises,

- Replace oxygen sensor and re-test.

### If CO content does **not** rise,

- Check for continuity of wire to terminal 2 of the Digifant E.C.U.

### If continuity is **OK**,

- Replace the Digifant E.C.U. and re-test.

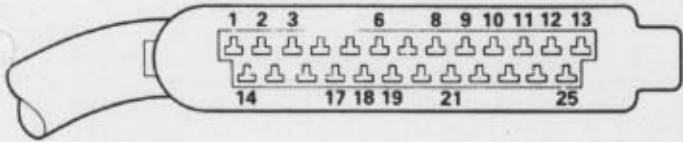

## Fuel Pump Checking

### Pressure Test

- Connect pressure gauge US 1076 or VW 1318 (or equivalent) to fuel line T-piece.

**Note:**

If using VW 1318 pressure gauge, the lever must be in a closed position.

- Remove fuel pump relay and bridge terminals 30 and 87 with tool US 4480/3.
- Run fuel pump and observe pressure.
  - Pressure must be a minimum of 2.5 bar (36 PSI).

If not OK,

- Continue with next test.

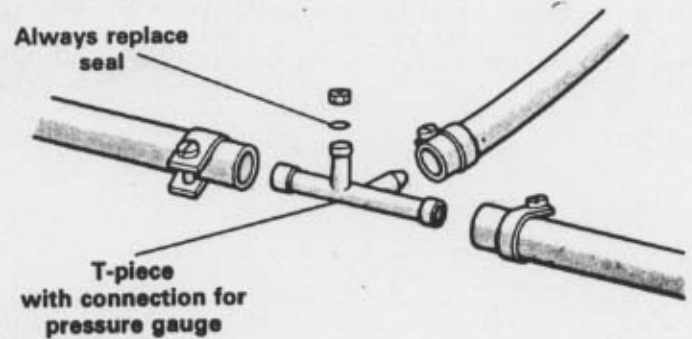

### Volume Test (Fuel Tank At Least Half Full)

- Disconnect fuel return line at pressure regulator.
- Attach approx. 4 feet of fuel line to return line of pressure regulator. Place other end of fuel line into a 1 liter measuring container.
- Remove fuel pump relay and bridge terminals 30 and 87 with tool US 4480/3.
- Run fuel pump exactly 30 seconds.

- Delivery quantity should be at least 500 cc.

If delivery quantity is not to specifications, check fuel flow from tank before and after fuel filters.

If fuel flow from tank is not obstructed, continue to Fuel Pump Electrical Testing below.

### Fuel Pump Electrical

- Battery fully charged.
- Connect ammeter to fuel pump in series with power supply to fuel pump.
- Remove fuel pump relay, bridge terminals 30 and 87 with tool US 4480/3.

- Ammeter readings should be approximately 2.5 - 3.5 amps.

Lower reading may indicate poor ground.

Higher reading may indicate dragging pump motor, pump must be replaced.

## Fuel Pump — Checking (Cont'd.)

### Wiring Check

#### Requirements

- Relay installed.
- Switch the ignition ON.
- Check terminal 87a of the power supply relay for battery voltage.

If there is **no** voltage,

- Check continuity of the wire to terminal 15 of the ignition coil.

If the voltage was **OK**,

- Check terminal 30 of the power supply relay for battery voltage.

If there is **no** voltage,

- Check continuity of the wire to terminal B+

on the alternator.

If the voltage was **OK**,

- Check terminal 85 of the power supply relay for ground.

If the ground circuit is **not OK**,

- Check continuity of the wire to ground on the left side to the engine compartment.

If the ground circuit was **OK**,

- Check terminals 86 and 87 of the power supply relay for battery voltage.

If there is **no** voltage,

- Replace the power supply relay.

### Fuel Pump Relay

- Ignition coil produces spark while cranking starter.
- Check terminals 86 and 30 of fuel pump relay for battery voltage.
- Remove fuel pump relay and check terminal 85 for ground from terminal 3 of the Digifant E.C.U. while cranking the starter.

If **not OK**,

- Check continuity of wire from terminal 85 of fuel pump relay socket to terminal 3 of the Digifant E.C.U.

If the continuity is **OK**,

- Replace the Digifant E.C.U.
- Re-install the fuel pump relay.

- Switch the ignition OFF and then back ON.
- Check terminal 87 for battery voltage. (Battery voltage will only be present for about 5 seconds after switching the ignition ON.)

If **no** voltage is present,

- Replace the fuel pump relay.

If the voltage is **OK**,

- Check continuity of the wiring from the fuel pump to ground and to terminal 87 of the fuel pump relay.

If the continuity is **OK**,

- Replace the fuel pump.

## Fuel Pressure Regulator Checking

- Connect pressure gauge US 1076 or VW 1318 (or equivalent) to fuel line T-Piece.

**Note:**

If using VW 1318 pressure gauge, the lever must be in a closed position during measurement procedure.

- Run engine at idle speed and check pressure.

Specifications:

Bar (P.S.I.)	Vacuum Hose on Pressure Regulator
2.2 (33)	Connected
2.5 (36)	Disconnected

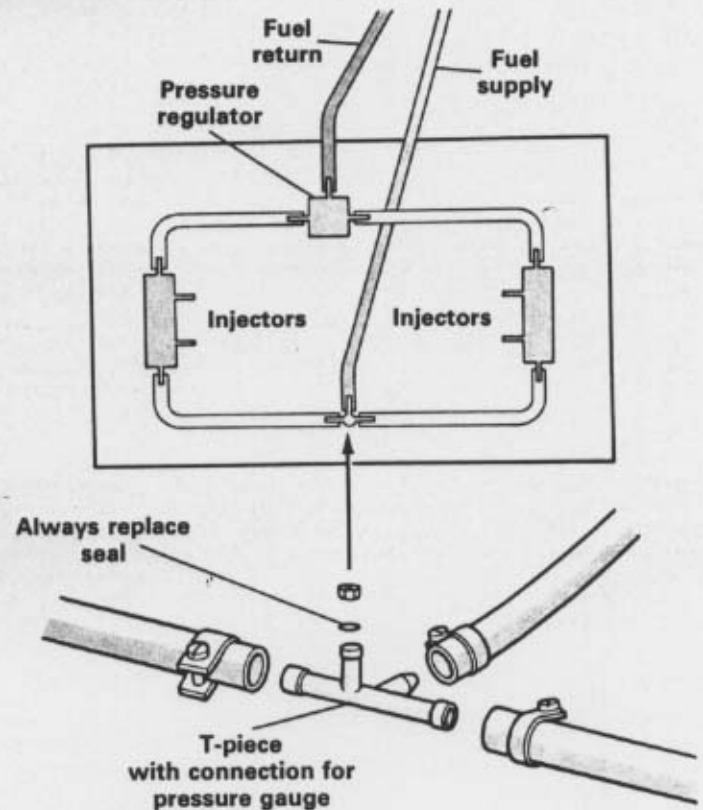

## Residual Pressure Test

- Stop engine, wait 10 minutes. Pressure should be 2.0 - 2.5 bar (29-36 PSI). If not, there are three possible problems:
  - Fuel pump check valve - Test by clamping off line from fuel pump.
  - Fuel pressure regulator - Test by clamping off return line to tank.
  - Fuel injector(s) - Test by clamping off lines from injectors to pressure regulator. If necessary, go to page 20 for instructions on leak testing individual injectors.

- Observe pressure gauge while clamping off each of these individual lines. If pressure drop ceases or slows dramatically, problem is in the indicated component. Use care not to damage lines with clamping device.



# Checking/Adjusting

## Ignition System Checking

If there is no spark at terminal #4 of the ignition coil when cranking the engine, do the following checks:

- Check for battery voltage at terminal 15 of ignition coil with ignition ON.

If **no** voltage present,

- Repair wiring using wiring diagram.

If voltage is present,

- Connect US 1115 L.E.D. Tester to terminal 1 of ignition coil and crank engine.
  - Diode must flash while cranking.

If diode flashes,

- Replace ignition coil.

If diode does not flash,

- Check Hall system as follows:

### Part A

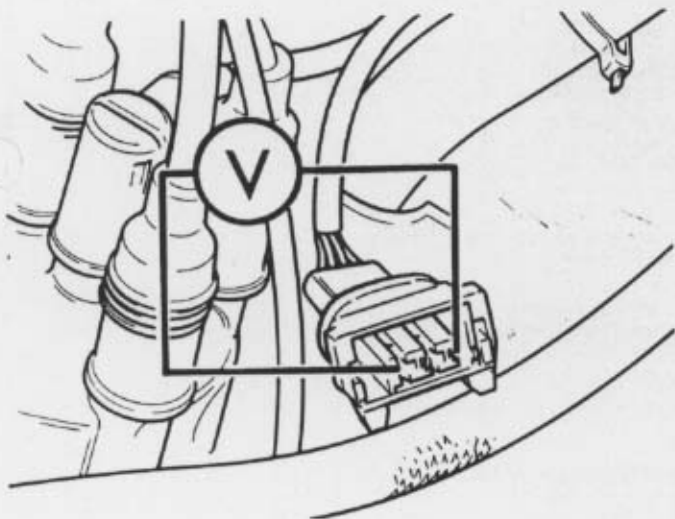

- Remove the wiring connector from the distributor.
- Switch the ignition ON.
- Measure voltage at outer terminals of wiring connector.
  - Reading should be a minimum of 5 Volts.

If voltage is present, go to Part B, next page.

If voltage is **not** present at the outer terminals,

- Remove the wiring connector from the Digifant E.C.U. and check for battery voltage across terminals 13 and 14.

## Ignition System Checking (Cont'd.)

If voltage is **not** present across Digifant E.C.U. connector terminals 13 and 14,

- Repair the wiring using wiring diagram.

If voltage is present across E.C.U. terminals 13 and 14,

- Check the wire from terminal 6 of the Digifant E.C.U. to terminal 1 at the distributor connector (BR/W wire).

If there is **no** continuity,

- Repair wiring using wiring diagram.

If there is continuity,

- Check wire from terminal 8 of the Digifant E.C.U. to terminal 3 at the distributor connector (R/BK wire).

If there is **no** continuity,

- Repair wiring using wiring diagram.

If there is continuity,

- Replace the Digifant E.C.U. and re-test.

### Part B

- Reconnect wiring connector to distributor and peel back rubber boot.
- Connect a voltmeter between the center terminal of the wiring connector and battery.
- Crank engine with starter.
  - Voltmeter reading should fluctuate.

If the voltmeter reading does **not** fluctuate,

- Replace Hall sender and re-test.

If voltage reading fluctuates,

- Check continuity of the wiring between the center terminal (G wire) of the distributor wiring connector and terminal 18 of the Digifant E.C.U.

If wiring is OK, replace Digifant E.C.U.

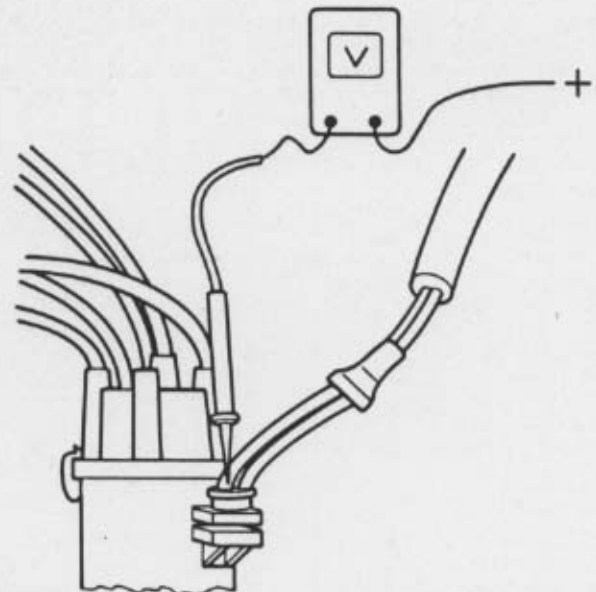

# Checking/Adjusting

## Idle Stabilization — Checking

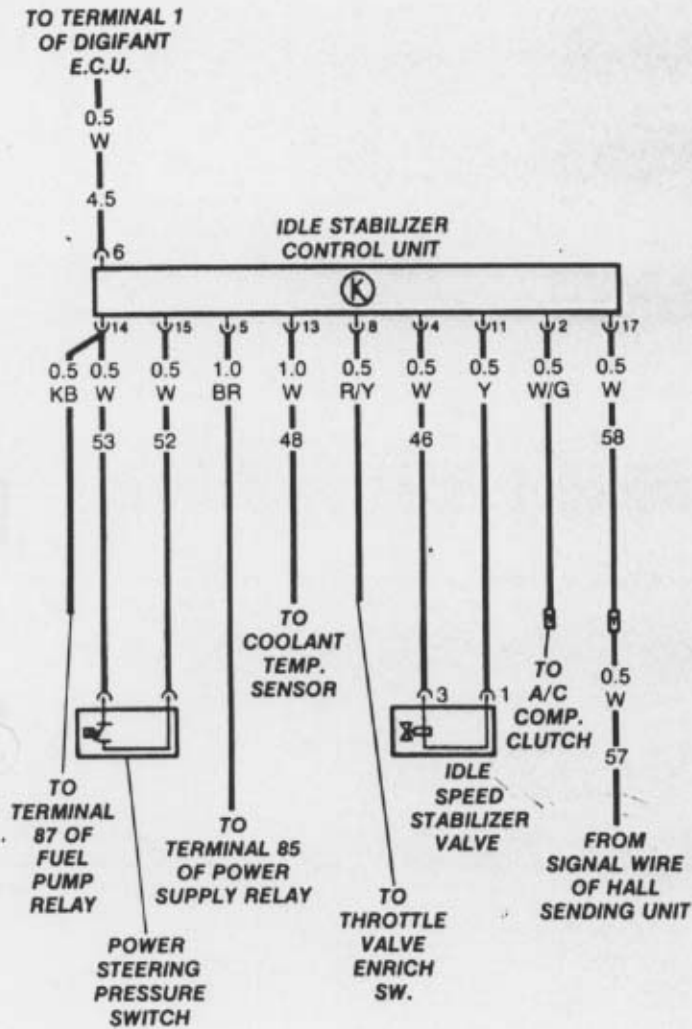

- Engine at operating temperature (oil temp. at least 80° C [176° F]).
- Throttle switch connected and functioning properly.
- All electrical consumers OFF and radiator cooling fan not running when observing readings.

- Connect US 1119 to the idle stabilization valve using test adapter VW 1315A/2 and set meter to 2 amp scale. (Reading will be in milliamps).
- Run the engine at idle and observe readings.
  - Basic value is 430 mA + 20 mA and slowly fluctuating.

If **not OK**, go to Idle Speed/CO Content - Checking and Adjusting, page 37.

- If the milliamp reading is fixed (not fluctuating),
  - Check for signal from terminal 1 of ignition coil at connector for idle stabilization control unit as follows:
    - Connect US 1115 L.E.D. Tester between terminals 5 and 17 of connector.
    - Crank engine over with starter.
      - L.E.D. Tester must flash while cranking.



# Checking/Adjusting

---

## Idle Stabilization — Checking (Cont'd.)

The amount of increase in the milliamp readings for the following steps is dependent on many factors. Of primary concern is that the milliamp readings do **increase** for each step. This indicates that the idle stabilization control unit is compensating for load changes.

If the idle stabilization control unit is functioning properly but the idle lowers drastically or the engine stalls when a load is applied, the problem is with the idle stabilizer valve itself.

## Milliamp Increases While Cranking Starter

### Requirements

- Idle stabilizer valve **OK** (the valve must vibrate and hum with the engine running).
- Connect digital multimeter to idle stabilizer using adapter VW 1315A/2 and set to 5 or 10 amp. scale (reading will be in milliamps).
- Ground ignition coil terminal #4.
- Crank starter motor.
- Stabilizer current should increase beyond 430 mA while cranking starter.

### If not OK,

- Disconnect multi-pin connector from the Digifant E.C.U.

- Check the continuity of the wire from terminal 6 of the idle stabilizer control unit connector to terminal 1 of the E.C.U. connector.

If the continuity is **OK**,

- Check the continuity of the wire from terminal 1 of the E.C.U. connector to terminal 50 of the starter motor.

If the continuity is **OK**,

- Replace the Digifant E.C.U. and re-test.

## Idle Stabilization System — Checking (Cont'd.)

### Air Conditioning

- Connect VW 1315/2 and US 1119 to idle stabilizer valve and set meter to mA scale.
- Start engine and let idle.
- Switch A/C ON while observing multimeter.
  - Milliamp reading should increase.

If milliamp reading does **not** increase,

- Remove idle stabilization control unit.
- Connect US 1115 L.E.D. Tester between terminals 2 and 5 of idle stabilization control unit connector.

- Start engine and switch A/C ON and OFF.
  - L.E.D. must light when the A/C is ON and go out when the A/C is OFF.

If **OK**,

- Replace idle stabilization control valve.

If **not OK**,

- Check wiring from A/C compressor clutch to terminal 2 of idle stabilization control unit connector.
- Check that A/C compressor clutch is functioning properly; repair, if necessary, and re-test.

### Power Steering

- Connect VW 1315/2 and US 1119 to idle stabilizer valve and set meter to mA scale.
- Start engine and let idle.
- Turn steering wheel hard to the left (or right) to stop while observing multimeter.
  - Milliamp reading should increase.

If milliamp reading does **not** increase,

- Bridge the terminals of the power steering pressure switch with a jumper wire.
  - Milliamp should increase.

If the milliamp reading **does** increase,

- Replace the power steering pressure switch and re-test without a jumper wire. If still no milliamp increase,

- Check the steering pump pressure.

If the milliamp reading does **not** increase,

- Switch the ignition OFF.
- Check continuity of the wiring from the power steering switch to terminals 14 and 15 of the idle stabilizer control unit using the wiring diagram.

If the continuity is **OK**,

- Replace the idle stabilization control unit and re-test.

# Checking/Adjusting

## Evaporative Emission System — Checking Control Valve

Engine idling, at normal operating temperature.

- Remove white nylon purge line from rubber boot at right rear of intake air distributor.
- Connect vacuum pump US 8026 or equivalent to open end of purge line and apply 5-10 in. Hg of vacuum.
  - Control valve must maintain vacuum.

If **no**,

- Remove purple vacuum line from fitting on throttle body and install vacuum pump US 8026 or equivalent.
  - At idle, there should be 0 in. Hg (up to 1 in. Hg vacuum is acceptable)

If **OK**,

- Replace control valve.

If **not OK**,

- Adjust throttle valve stop screw (According to page 13).
- Repeat first check.
  - The control valve should maintain vacuum at idle.
- Accelerate engine by hand.
  - Control valve must release vacuum.

If **not OK**, either vacuum fitting on throttle body is plugged or control valve is stuck in the closed position.

## Evaporative Emission System — Checking For Leaks

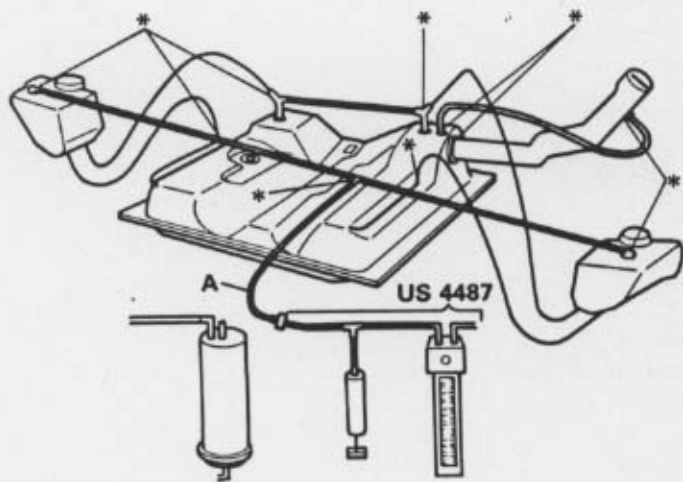

- Remove small hose "A" from top of charcoal filter. Connect to leak tester US 4487.
- Set leak tester scale to "0".
- Pressurize system with hand pump to 3.3 cm (1.3 in.) of mercury.
  - system okay if pressure is 2.54 cm (1.0 in.) or greater after 5 minutes.
  - system leaking if pressure drops below 2.54 cm (1.0 in.) after 5 minutes.

**Note:** Check system for leaks using soap solution at spots marked with \*. Seal if necessary.

# Basic Engine Adjustments

## Specifications/Adjustments

### Basic Settings

#### Note:

Check and adjust the basic engine settings in the following order:

- ignition timing
- idle speed
- CO content

#### Test and adjustment conditions:

- Engine oil temperature minimum 80°C (176°F).
- All electrical consumers switched OFF (radiator cooling fan should not be running while performing checks and adjustments).
- Crankcase breather hose removed from breather valve and plugged.
- Throttle valve switch operating properly (closed in idle position).
- Idle stabilizer operating properly (with engine idling, valve should vibrate and hum).
- Throttle stop screw is properly adjusted.

#### Connecting test equipment:

#### WARNING

Switch ignition OFF when connecting test equipment.

- Connect VW 1367 using adapter VW 1473 to connect tester to terminal 1 of the ignition coil.
- Connect CO tester to fitting on left exhaust pipe using **only** adapter Sun 120.239 or equivalent (with high temperature silicone connecting hose).

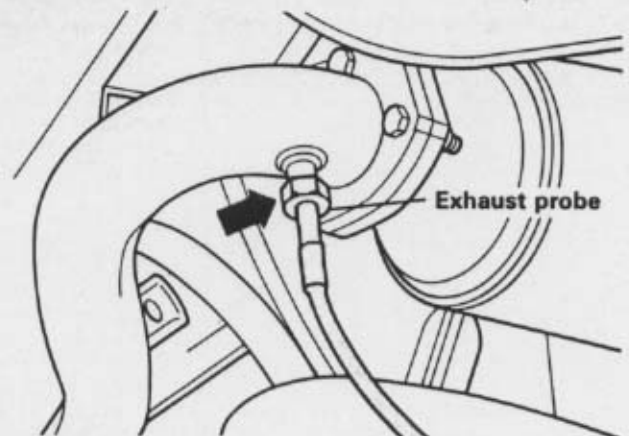
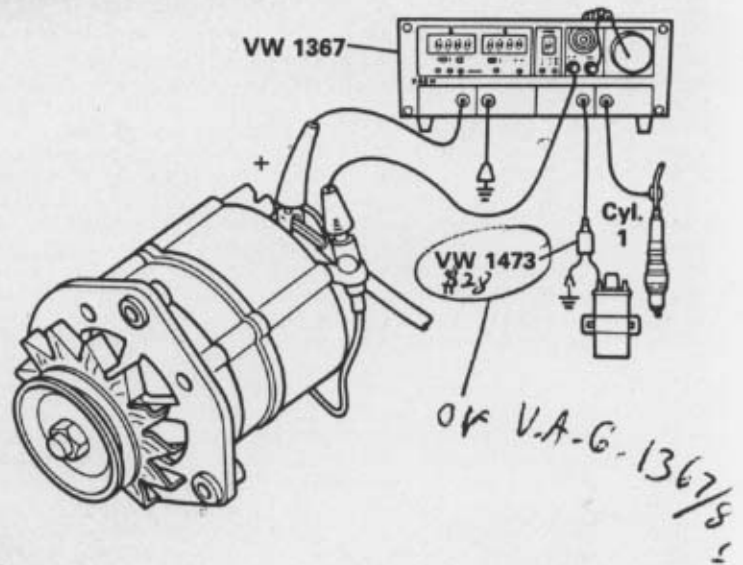

#### Note:

Non-approved hoses may dramatically alter your readings.

Non-approved hoses may overheat and create vapors that will cause false CO% readings.



# Basic Engine Adjustments

---

## Specifications/Adjustments (Cont'd.)

### Ignition Timing — Checking/Adjusting

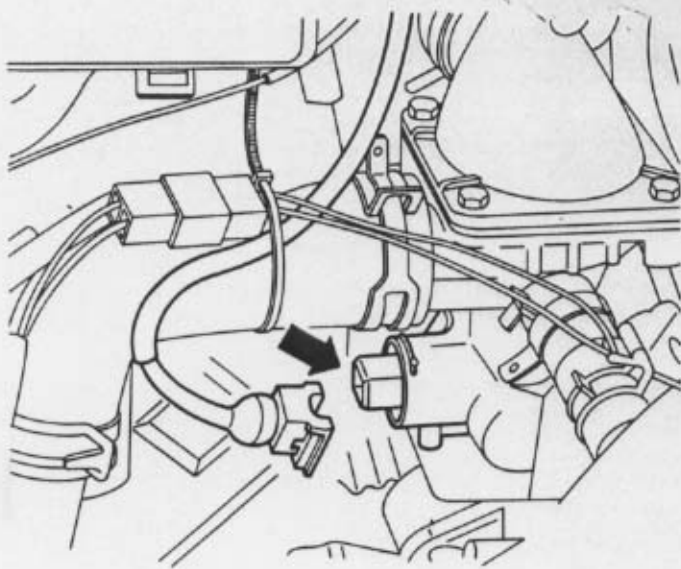

With engine idling:

- Disconnect coolant temperature sensor (arrow).

#### **Caution**

Do not let temperature sensor connector hang down on exhaust manifold.

- Increase engine speed to  $2300 \pm 200$  RPM and observe reading.
  - Checking  $3^\circ$  to  $7^\circ$  BTDC
  - Adjusting  $5^\circ \pm 1^\circ$  BTDC
- Reconnect coolant temperature sensor.
- Increase engine speed to 3500 RPM and observe reading.
  - $40^\circ \pm 5^\circ$  BTDC (timing must advance  $35^\circ$  from base setting).

If **not OK**,

- Replace Digifant E.C.U. and re-test.

# Basic Engine Adjustments

## Specifications/Adjustments (Cont'd.)

### Idle Speed And CO Content — Checking And Adjusting

With ignition switched OFF:

- Disconnect the oxygen sensor.

**Note:**

The oxygen sensor must be disconnected with the ignition OFF to cancel the memory function of the Digifant E.C.U.

- Connect US 1119 to idle stabilizer using adapter harness VW 1315A/2.
- Set US 1119 to 2 amp scale (reading will be in milliamps).
- Run engine at Idle and observe the readings.
  - With idle speed of  $880 \pm 50$  RPM (coolant fan not running), the milliamp reading should be  $430 \pm 20$  milliamps.

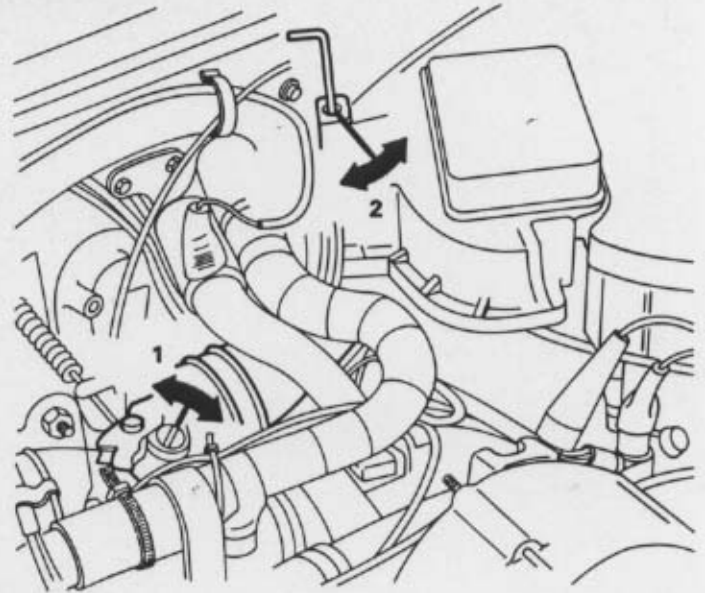

If not OK,

- Adjust to specification by turning the idle adjusting screw on the throttle housing (1.)

**Note:**

Turning the idle adjusting (1) screw **out** will lower the milliamp reading. Turning the idle screw **in** will raise the milliamp reading.

Always allow time for the reading to stabilize when checking or adjusting.

# Basic Engine Adjustments

## Specifications/Adjustments (Cont'd.)

### Idle Speed And CO Content — Checking And Adjusting

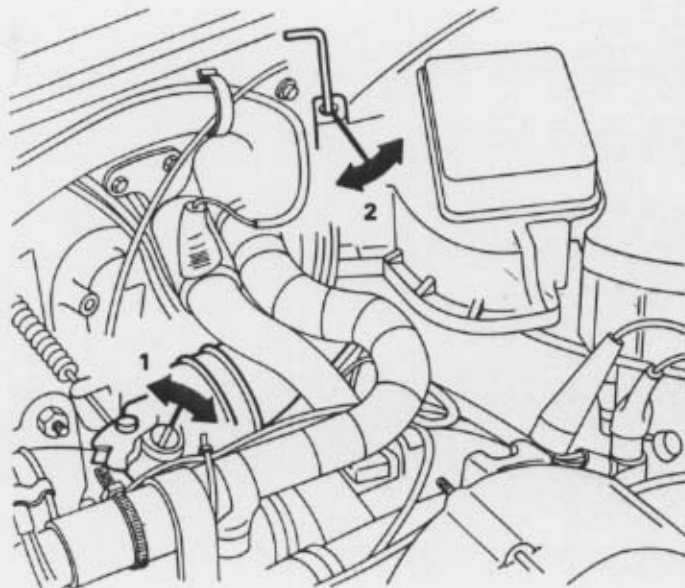
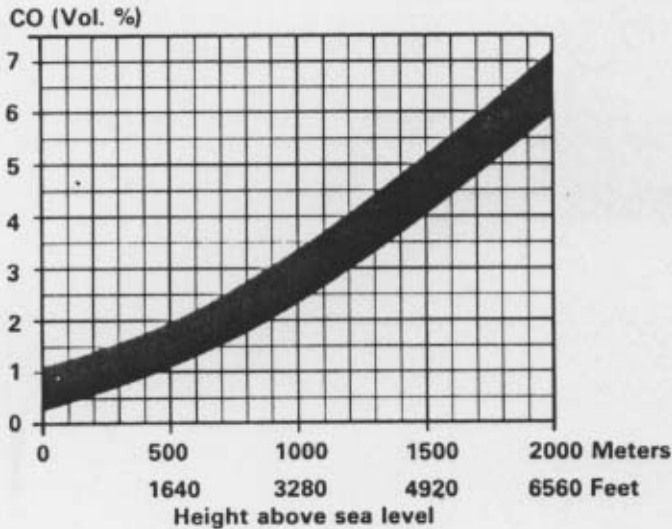

- Check the CO and HC values.
  - CO should be 0.3%- 1.2% at sea level. (For altitudes above sea level, use the graph.)

#### If not OK,

- Correct the base CO setting by turning the CO adjusting screw in the air flow sensor housing.

#### Note:

To adjust the CO, remove tamper-proof plug as follows:

- Drill plug using 2.5 mm (0.098 in.) bit.
- Thread 3 mm (0.137 in.) sheet metal screw into drilled hole.
- Grasp screw with pliers and pull plug out.
- Repeat idle and CO adjustments until both are within specifications.
- Reconnect oxygen sensor.
  - CO reading must go to  $0.7\% \pm 0.4\%$  (at any altitude).

#### If not OK,

- Check oxygen sensor function (page 24).
- Install a new tamper-proof plug over the CO adjusting screw.

# Basic Engine Adjustments

## Specifications/Adjustments (Cont'd.)

- Re-check the idle speed setting as follows:
- Disconnect the yellow in-line idle stabilizer control unit connector in the engine compartment.
  - Milliamp reading must be approximately 430 mA and fixed (non-fluctuating).
  - Idle speed should remain steady at  $880 \pm 50$  RPM.

If **not OK**,

- Repeat idle set and CO procedure.

If still **not OK**,

- Check the idle stabilization system (page 30).

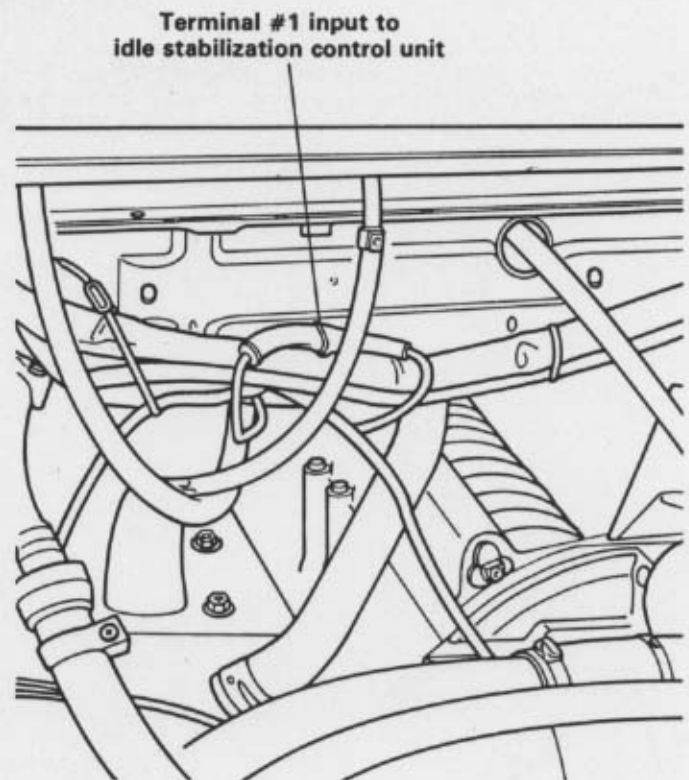

# System Check With Volt/Ohmmeter

## System Check With Volt/Ohmmeter

The entire Digifant electrical system can be checked by measuring voltage and resistance at the Digifant E.C.U. multi-pin connector.

OHMMETER TO TERMINAL	COMPONENTS	CHECKS/TEST CONDITIONS	SPECIFICATIONS
2 and 13	Oxygen Sensor	<ul style="list-style-type: none"> <li>• Connector Disconnected and Grounded</li> <li>• Connector Connected</li> </ul>	0 ohms ∞ ohms
6 and 9	Temp. Sensor I (Intake Air Temp.)	• Resistance	Corresponding with graph.
6 and 10	Temp. Sensor II (Coolant Temp.)	• Resistance	
6 and 11	Throttle Switch	<ul style="list-style-type: none"> <li>• Idle Position</li> <li>• Full Throttle Position</li> </ul>	0 ohms 0 ohms
6 and 17	Air Flow Sensor	• Total Resistance	500 to 1000 ohms
17 and 21	Air Flow Sensor	• Resistance Through the Potentiometer	Ohms fluctuate as sensor plate is opened
#12 at ECU and #87 at Fuel Pump Relay	Fuel Injectors and Wiring	• Total Resistance	3 to 5 ohms
Check at Components	Individual Fuel Injectors	• Resistance (Each)	14 to 18 ohms
13 and Ground	Control Unit Ground Connection	• Wiring	0 ohms

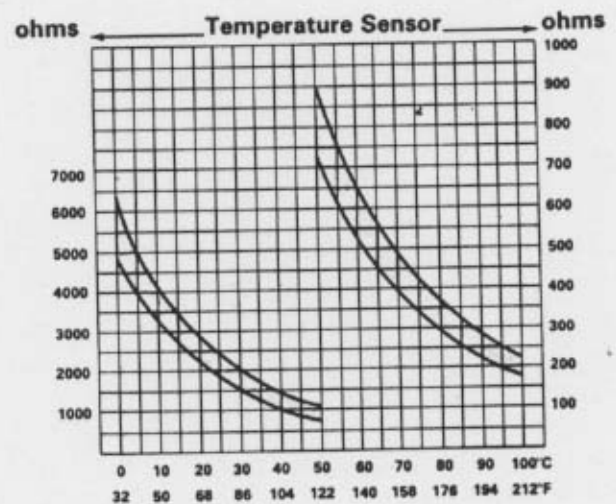
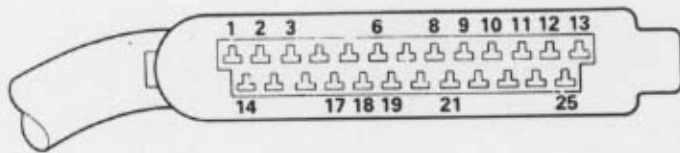

# System Check With Volt/Ohmmeter

## System Check With Volt/Ohmmeter (Cont'd.)

VOLTMETER TO TERMINAL	COMPONENTS	CHECKS/TEST CONDITIONS	SPECIFICATIONS
1 and 13	Wiring from Starter	• Voltage from Terminal 50 During Cranking (Starting Injection)	Cranking voltage
3 and 13 Bridged	Fuel Pump Relay	• Ignition ON	Fuel pumps run
13 and 14	Power Supply Relay	• Ignition ON	Battery voltage

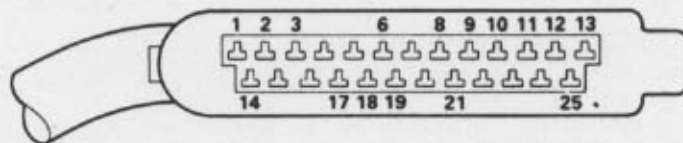

# Wiring Diagram

30  
15  
X  
31

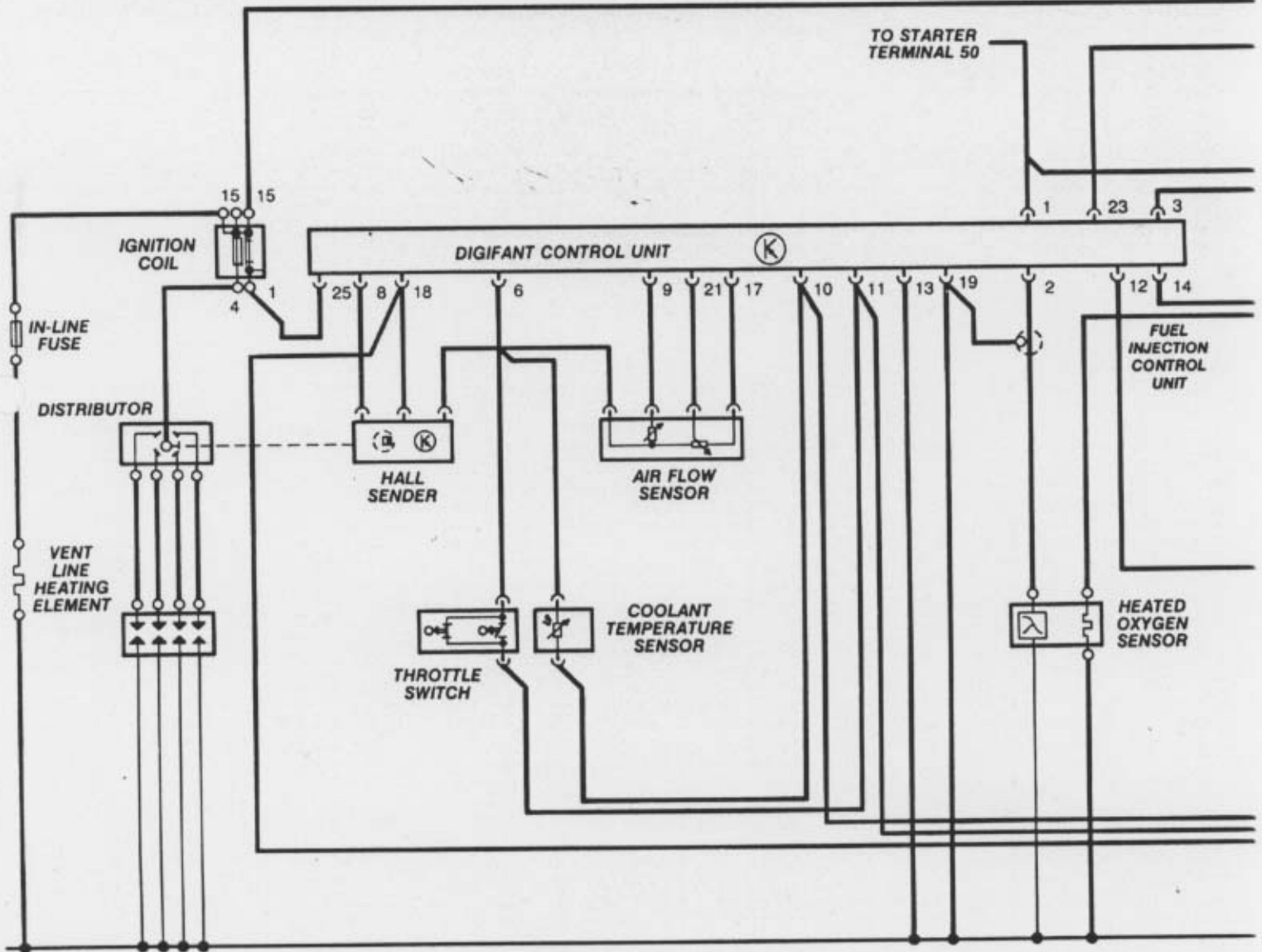

# Wiring Diagram

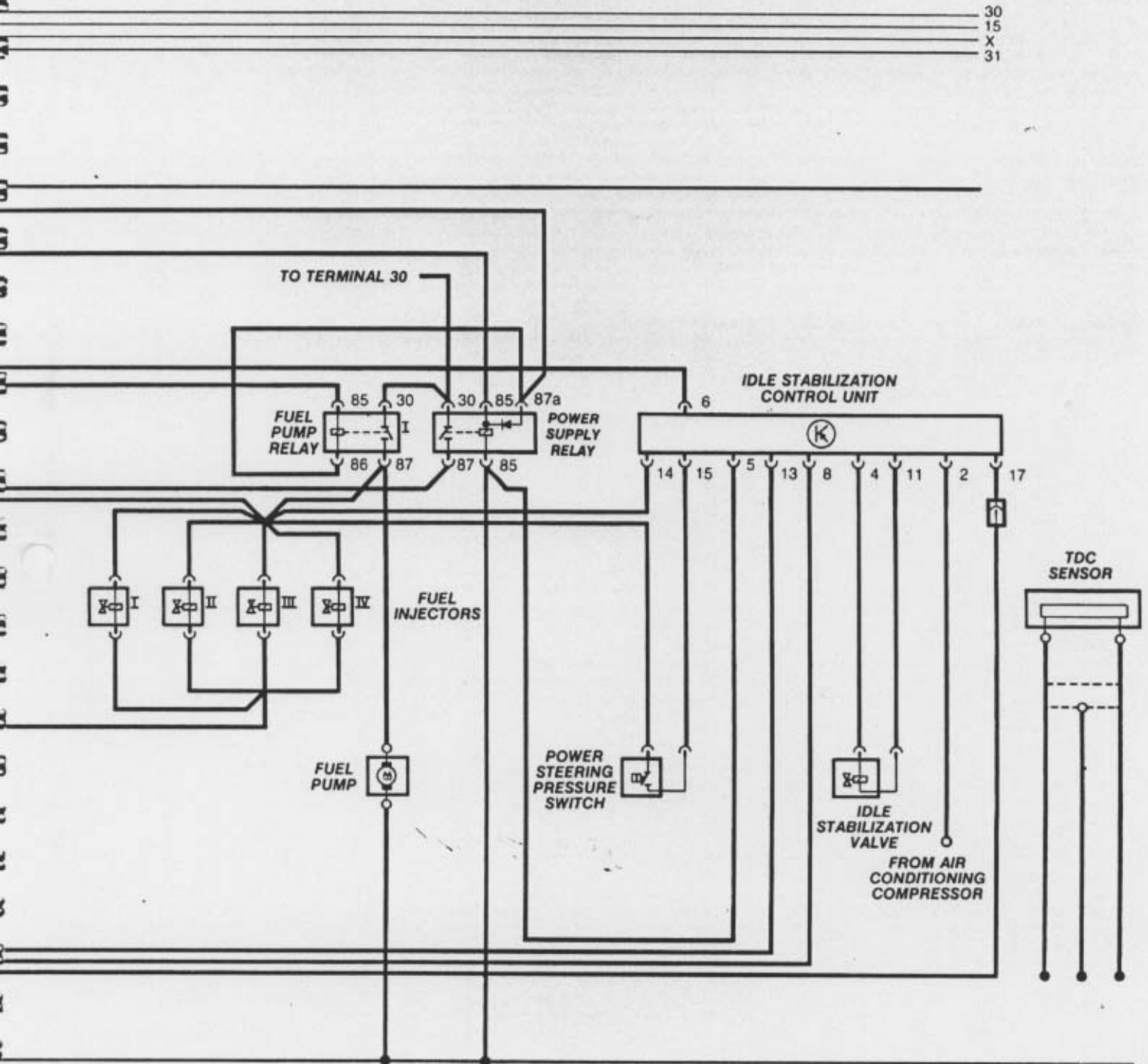



# Special Tools Required

---

## Minimum Requirement

- US 1115 L.E.D. Test Light (Leads must be connected RED to positive and Black to negative)
- VW 1367 Tester
- US 1119 Multi-Meter (digital)
- US 1076 or VW 1318 with Adapter VW 1318/17 Pressure Gauge
- VW 1473 Voltage Splitter
- Sun 120.239 CO Adapter
- VW 1315A/2 Adapter Harness
- Sun 105 CO Tester
- US 8026 Hand Vacuum Pump
- US 4487 Evaporator System Leak Tester (slack tube)
- VW 1490 Resistance Block (15K ohms/0 ohms)
- US 4480/3 Fuel Pump Switch (Optional)

## Obtain Locally

- 1 Liter Graduated Glass Container

# Glossary/Component Location

---

## **AIR FLOW SENSOR**

Measures the amount of air entering the intake manifold and sends a voltage signal to the electronic control unit. Location: attached to air filter housing.

## **BAR**

Unit of measurement pressure — 1 bar is approx. 14.5 PSI.

## **COOLANT TEMPERATURE SENSOR**

A sensor for measuring engine coolant temperature to determine cold running engine operation. Location: left, lower side of thermostat housing.

## **ELECTRONIC CONTROL UNIT (E.C.U.)**

Provides the proper actuation signal to the injectors and optimum ignition timing point based on inputs from other system components. Location: under left side of rear seat (inside vehicle).

## **FUEL FILTER**

A filter which removes foreign particles from the fuel system. Location: inboard side of right frame member, directly behind fuel pump.

## **FUEL PUMP**

An electric pump which delivers fuel to the injectors. Location: inboard side of right frame member, directly behind fuel tank.

## **FUEL PUMP RELAY**

When energized by the ignition switch and grounded by the Digifant E.C.U., the fuel pump relay provides battery voltage to the fuel pump, fuel injectors, idle stabilization control unit, oxygen sensor heating element, and power steering pressure switch. Location: It is the right side relay inside the black plastic relay box, directly above the ignition coil on the left side of the engine compartment.

## **IDLE STABILIZATION CONTROL UNIT**

Controls operation of idle stabilizer valve based on pre-programmed idle speed values and various other component inputs. Location: behind right rear taillight assembly, mounted just forward of air cleaner intake hose.

## **IDLE STABILIZATION VALVE**

Electronically controlled valve used to maintain idle speed at a pre-determined level by regulating intake air at idle. Location: rubber mounted to top of intake air distributor.

## **INJECTOR**

Electronically activated valve which directs a cone shaped mist of fuel into the intake port near each intake valve. Location: mount into intake manifold at cylinder head.

## **OXYGEN SENSOR**

Used to detect the amount of oxygen in the exhaust gases. Location: threads into catalytic converter housing.

## **OXYGEN SENSOR MILEAGE COUNTER**

Activates a warning light to indicate oxygen sensor replacement is required. Location: next to left side radius rod in front of vehicle.

# Glossary/Component Location

---

## **POWER SUPPLY RELAY**

When energized by the ignition switch, the power supply relay provides battery voltage to the Digifant E.C.U. Location: It is the left relay inside the plastic relay box, directly above the ignition coil on the left side of the engine compartment.

## **PRESSURE REGULATOR**

A diaphragm type regulator used to maintain system pressure at a given value. Location: bolted to rear of intake air distributor, directly adjacent to ignition distributor.

## **AIR FLAP POTENTIOMETER**

A variable resistor connected to the air flow sensor that provides a signal for determining fuel system enrichment. Location: internal component of air flow sensor (not available separately).

## **RESIDUAL PRESSURE**

Fuel pressure in the fuel injection lines after the engine has been turned off.

## **THROTTLE SWITCH**

Provides closed throttle and full throttle signals to E.C.U. for idle stabilization, deceleration fuel shut-off, and full load enrichment. Location: mounted to underside of throttle valve housing.