

1.8 ltr. engine with G-supercharger

Construction and Operation.

Self Study Programme No. 103

V·A·G

Service Department.

1.8 ltr. engine with G-supercharger

The new 1.8 ltr. engine means that Volkswagen can supply a sport engine of top class technology.

The increased power and good torque characteristics are achieved primarily thanks to the use of the mechanical G-60-supercharger.

The 118 kW (160 bhp) G-60-engine is based on the proven 79 kW GTI engine with 1.8 litre capacity.

In this new engine, the mixture preparation and ignition are performed by the Digifant fully electronic engine management system.

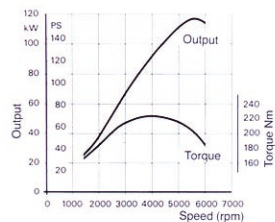
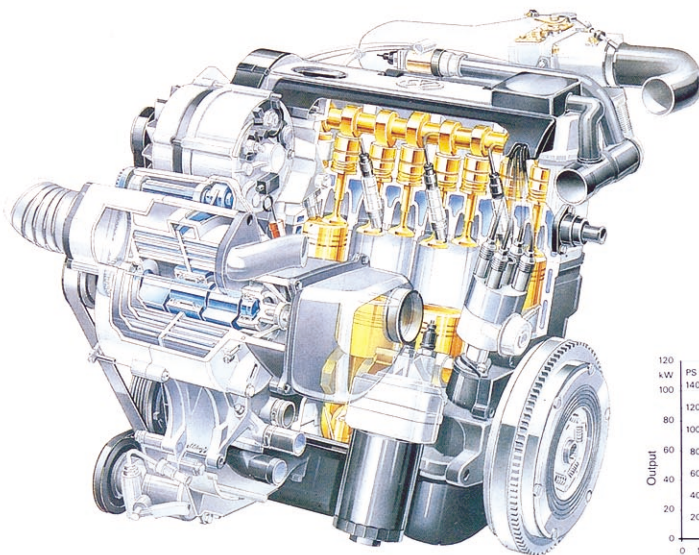

Contents

- **Fuel system**
- **Activated charcoal system**
- **Overview of the fully electronic engine management system**
- **Information senders/engine management**
- **G-supercharger / charge air cooling and bypass circuit**
- **Idle stabilization/boost pressure limiting system**
- **Ignition control**
- **Auxiliary functions**
 - **Fan run-on**
 - **Fuel pump run-on**

The test and repair instructions can be found in the Workshop Manual Corrado 1989 > and in the associated current flow diagrams.

Fuel system

Sender for fuel gauge

The fuel lift pump and the fuel gauge sender are incorporated into one unit.

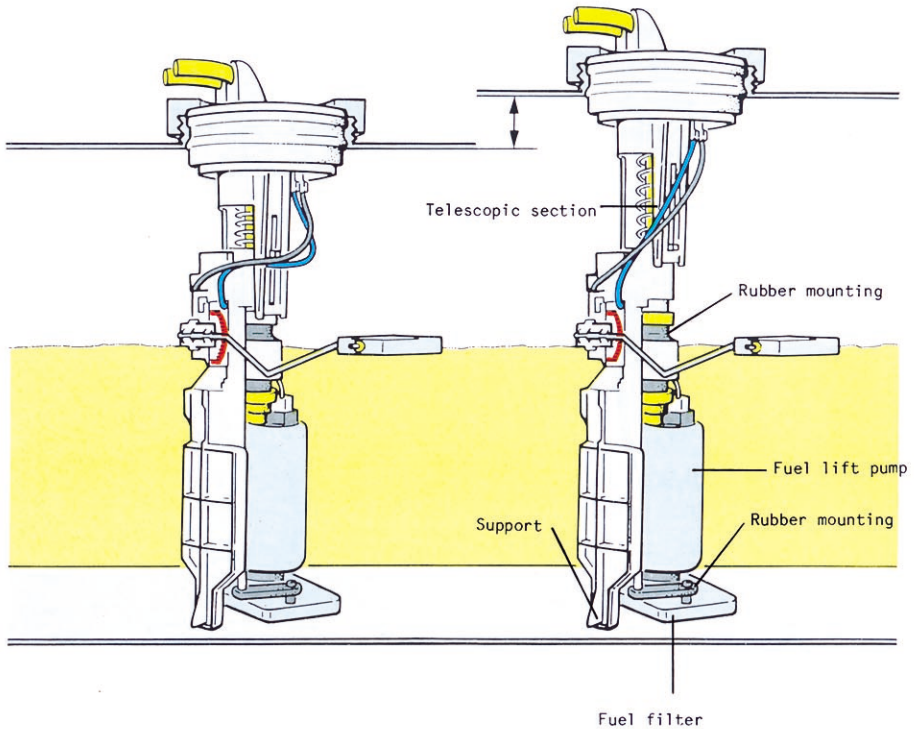

Any temperature-dependent expansion of the fuel tank is compensated by the telescopic effect in the shank of the fuel gauge sender. This guarantees that the correct resistance of the fuel gauge sender relating to the current fuel quantity is always sent to the fuel gauge. The new rubber mounting of the fuel pump reduces operating noise to a minimum.

The fuel pump, pump reservoir and fuel filter are mounted on a single carrier plate under the vehicle floor. The sturdy carrier plate serves primarily to protect the pump reservoir from any damage caused by accidents.

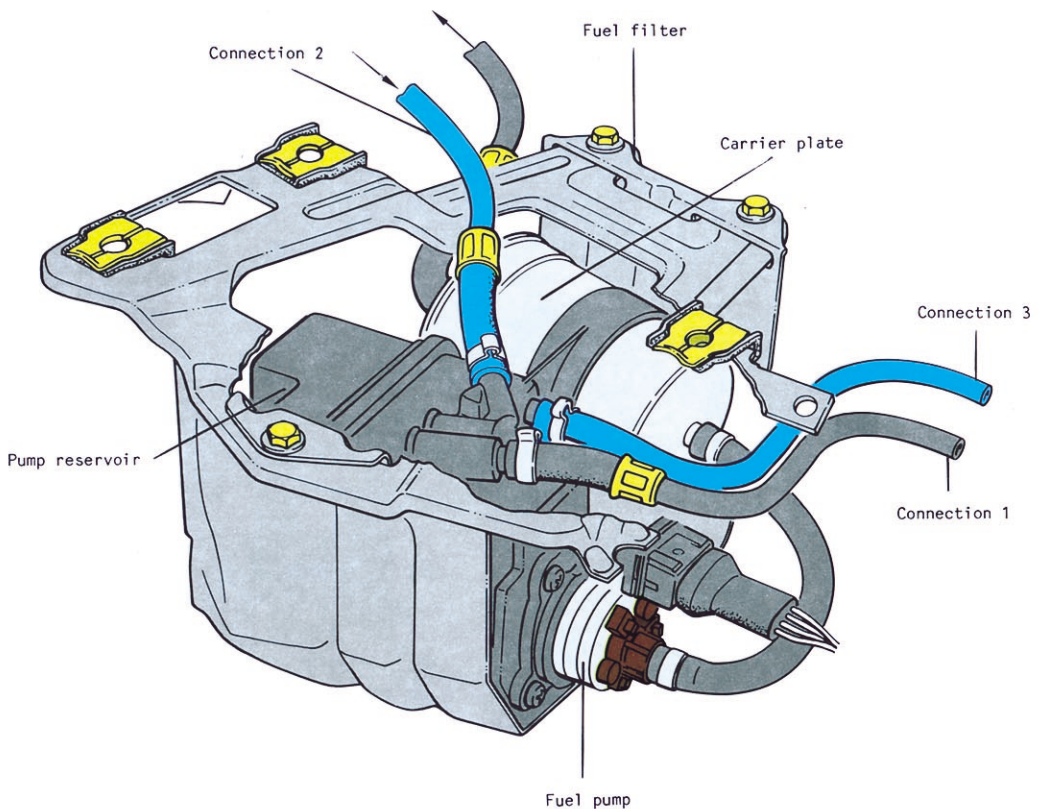

It works like this:

- o Fuel pump: The fuel pump is tuned to a fuel pressure of 3.0 bar. The well-known fuel pump from the Golf GTI with 79 kW engine is used.
- o Pump reservoir: The pump reservoir contains a fuel volume of approx. 700 cm³ and supplies the integral fuel pump with fuel free from vapour bubbles. Via connection 1, the fuel reaches the fuel lift pump in the pump reservoir, which operates constantly when the engine is running. Connection 2 collects the system's "return fuel" and the surplus fuel returns to the fuel reservoir from connection 3.
- o Fuel filter: The well-known maintenance-free fuel filter from other systems is used.

Fuel system

The fuel reaches the pump reservoir from the fuel lift pump integrated into the fuel tank. Within the supply volume (700 cm³) of the pump reservoir is the main supply pump which moves the fuel via the filter into the injector manifold. Plug connections mean that the injectors are integral components of the injector manifold. The return circuit of the fuel leads through the pressure regulator, via the pump reservoir to the fuel tank.

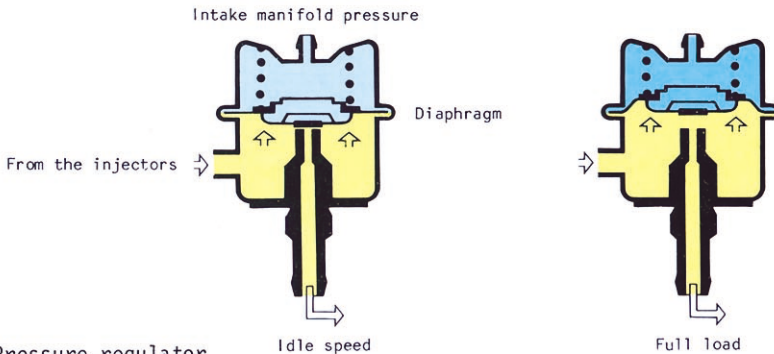
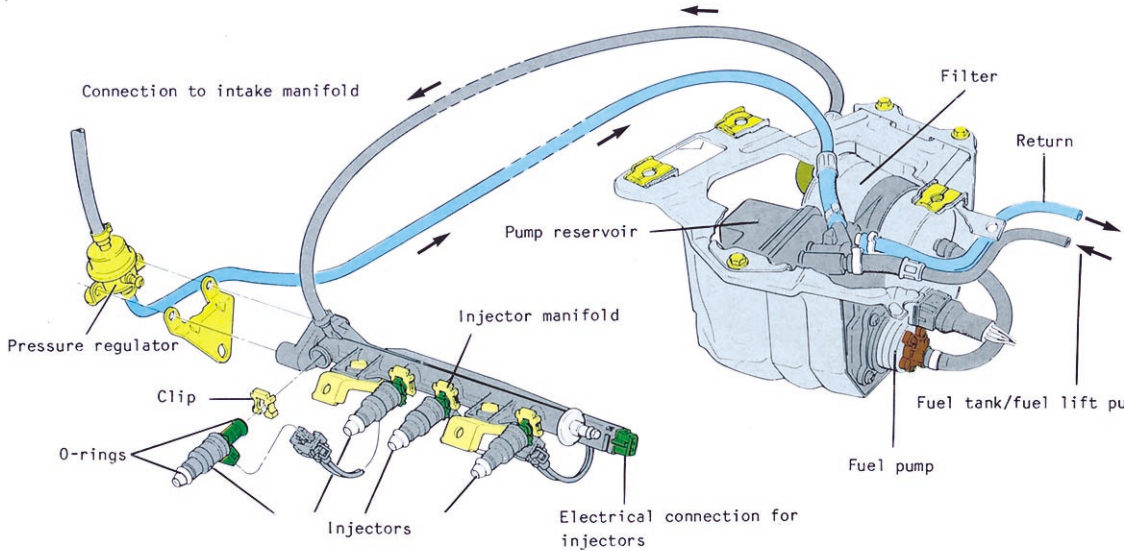

Pressure regulator

The intake manifold pressure influences the fuel pressure by means of the pressure regulator.

This means that e.g. in the case of low intake manifold pressure at idling speed, the fuel pressure similarly drops as the return to the tank is no longer open.

In full-load operation, the procedure is reversed.

This process ensures that the pressure difference (3 bar) between the intake manifold pressure and the fuel pressure remains constant and the varying intake manifold pressure has no influence on the injection quantity. In this way, the injection quantity can be dictated exclusively by the opening time of the injectors.

At idle speed, the fuel pressure is 2.5 bar and for full-load operation, 3.0 bar. A further function of the pressure regulator is to guarantee a holding pressure of approx. 2 bar for at least 10 minutes after the engine has been switched off.

Injector

The injector is designed as an electromagnetic valve. A four-hole plate and an additional guard cover protect the nozzle needle from deposits which may impair operation and also serve to dictate the spray pattern. The O-ring on the injector shank and at the tip of the injector guarantee a tight seal with the injector manifold and with the cylinder head.

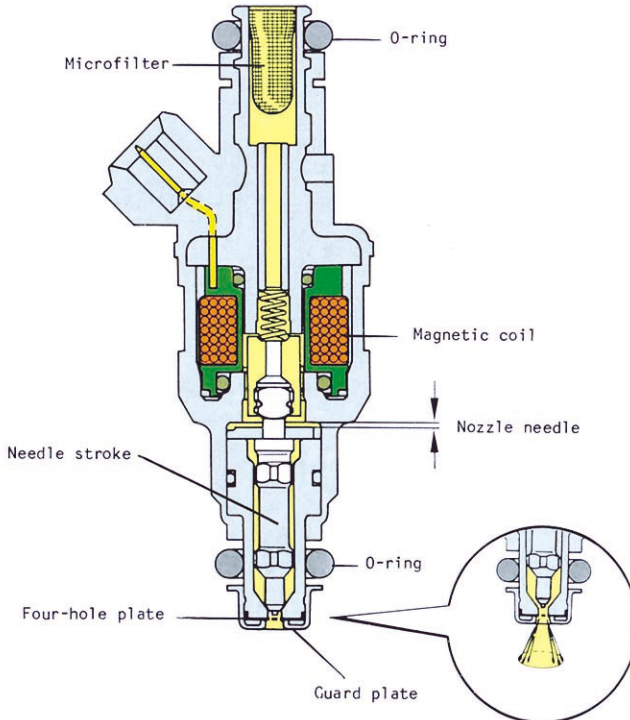

It works like this:

The fuel enters via the microfilter (pore width 0.06 mm). The opening time (2 - 16 ms) of the injector depends on the current operating state of the engine or the engine load and is controlled by the Digifant control unit. The stroke of the nozzle needle between the closed/open valve is < 0.06 mm (not adjustable). The fuel leaves via the four-hole plate and is restricted by the guard plate giving a fuel spray pattern or cone of 20 - 25 degrees. All injectors are activated simultaneously for each crankshaft revolution, with 50 % of the fuel quantity required for one operation being moved forwards and 50 % injected.

Activated charcoal system

Due to alternating temperature conditions, fuel vapours are produced primarily in the fuel tanks, which, in conventional ventilation and breathing systems, escape into the open air.

In order to avoid these vapour emissions and conform to various different legal requirements, activated charcoal systems have been introduced.

Any fuel vapours occurring travel from the fuel tank through a hose connection from the gravity valve at the tank filler neck, via the central connection a to the activated charcoal filter.

The activated charcoal is regenerated by fresh air when the engine is running in the part-load and full-load ranges.

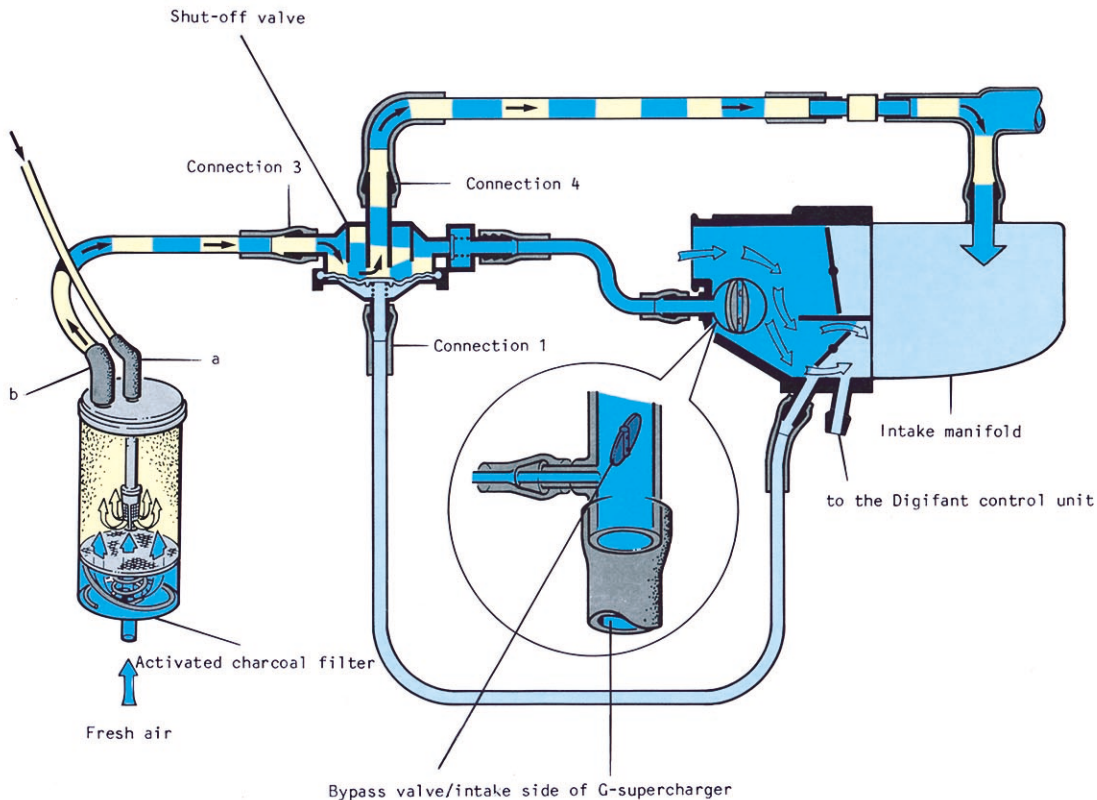

Part-load operation

In part-load operation, vacuum acts on connection 1 of the shut-off valve. The pneumatic shut-off valve opens between connections 3 and 4 and the fuel particles adhering to the activated charcoal are delivered to the engine via connection b of the activated charcoal filter.

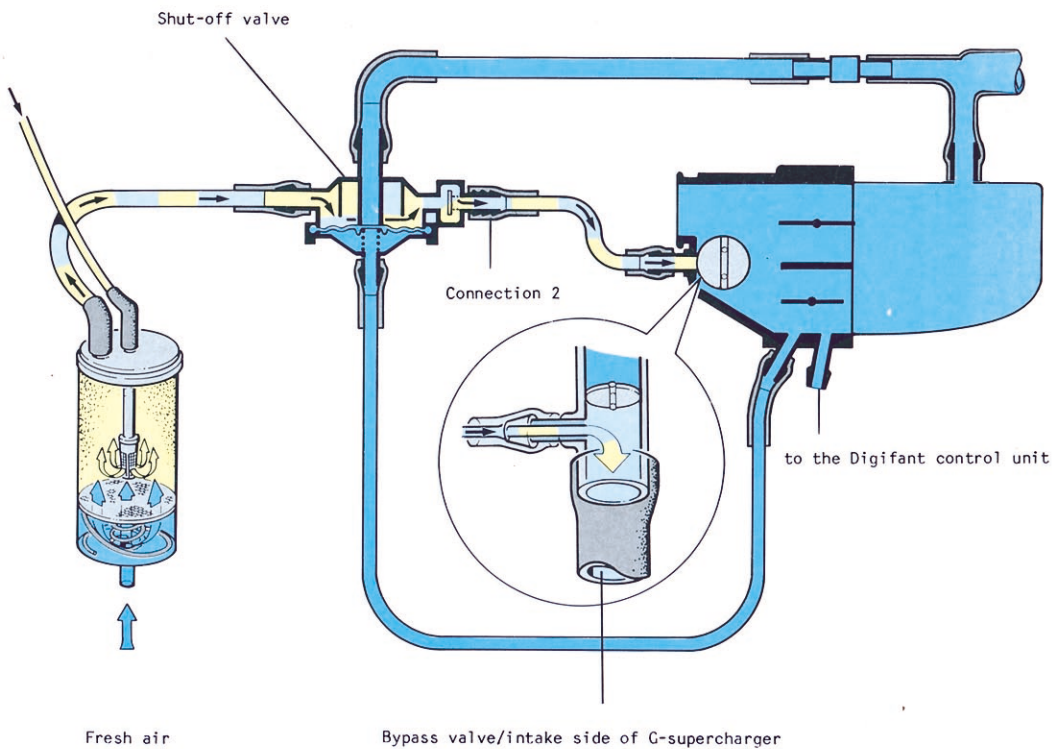

Full-load operation

In full-load operation, the bypass valve to the boost pressure control in the throttle valve housing is closed so that vacuum acts at connection 2. When the engine is running in this way, the fuel particles adhering to the activated charcoal on the intake side of the G-supercharger are delivered via the bypass line.

Engine management system

The Digifant fully electronic engine management system is used for the 1.8 ltr. engine with G-60-supercharger.
The individual systems for mixture formation, ignition control, overrun fuel cut-off, idle stabilization and boost pressure control are integrated into the Digifant control unit.

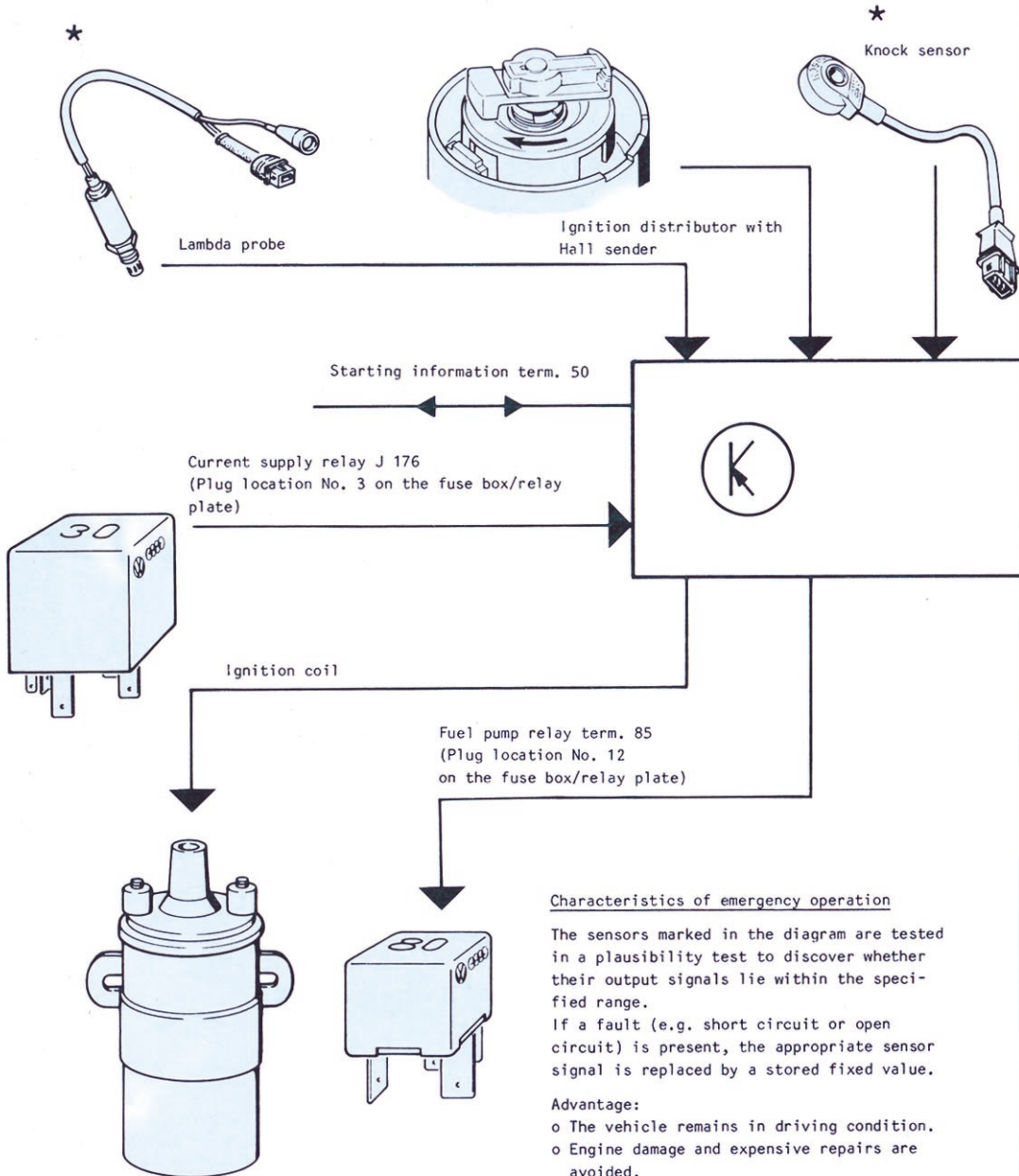

CO potentiometer ★
with air temperature sensor

Pressure sensor

Idle and full-load
switch

Coolant
temperature sensor

Automatic gearbox

Air conditioner compressor

Injectors

Valve for
idle stabilization and
boost pressure control

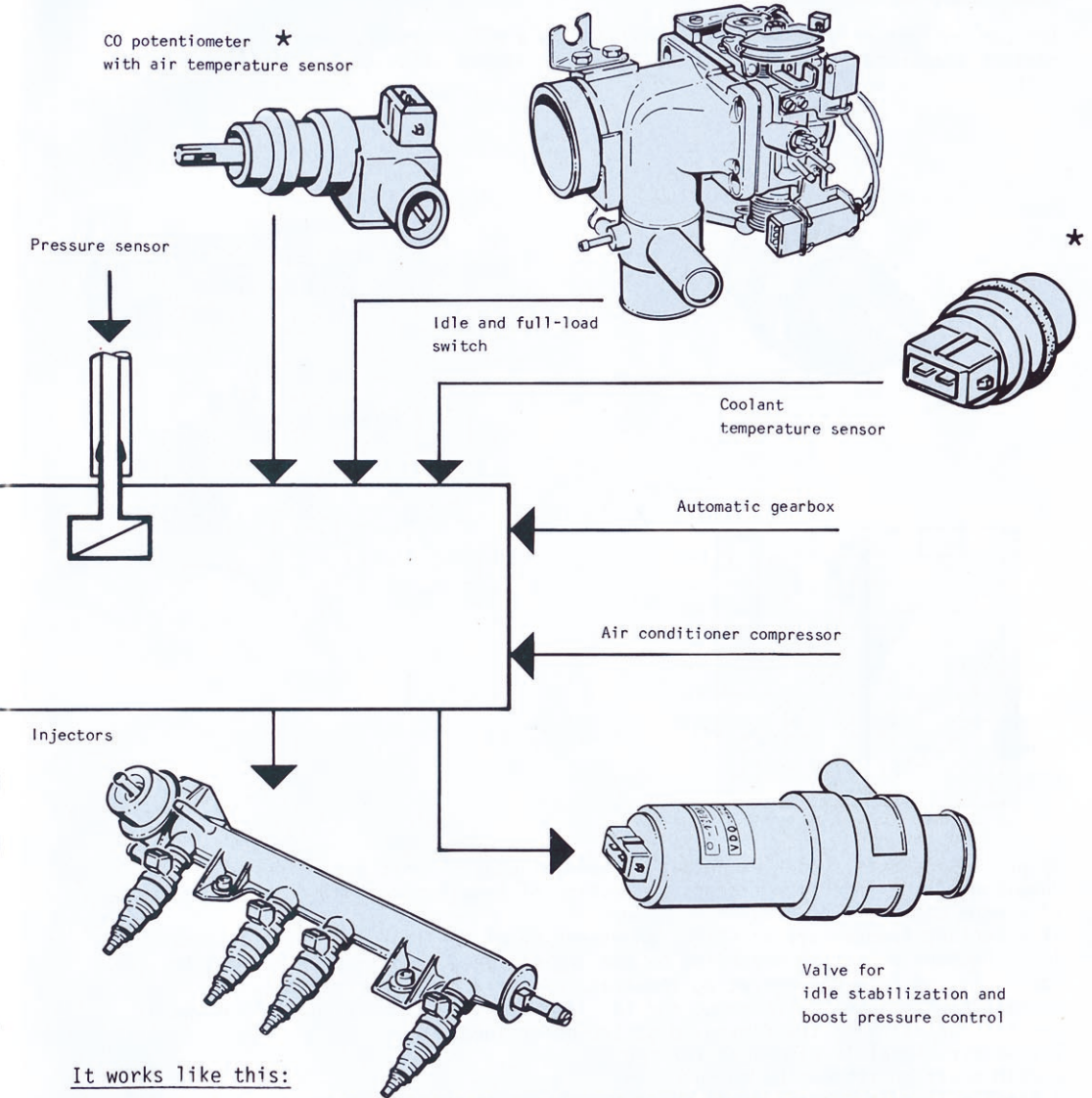

It works like this:

The engine speed signal from the Hall sender and the load signal from the pressure sensor form the basis for determining the engine-specific map. This basic map is corrected by information on coolant temperature and exhaust gas composition and is used to adjust the firing point and the injection time to the current operating condition.

With additional information on air temperature and throttle valve position from the idle and full-load switch, further adjustments are made to conform with engine conditions.

By means of voltage signals, the knock sensor informs the control unit of any knocking in combustion. Detection of the starting-up condition and factors affecting idling speed due to the operation of the air conditioner and the automatic gearbox are taken into account.

Information senders/engine management system

Coolant temperature sender

The coolant temperature sender is designed as a NTC resistor. According to the coolant temperature, it sends an assigned resistance value to the Digifant control unit.

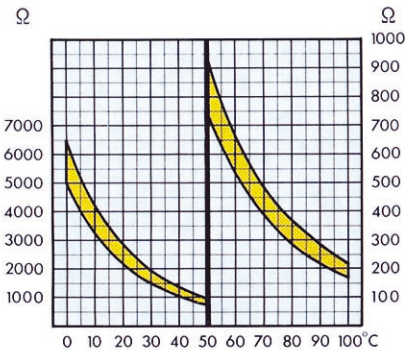
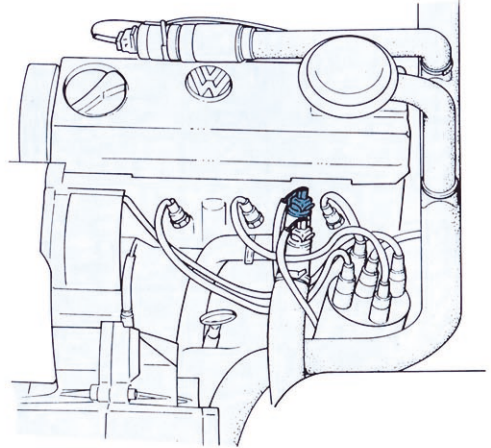

By processing this sender signal, the Digifant control unit determines the duration of the injection time as a function of temperature, which in the case of a warm engine, lies between 2 - 8 m/s.

At a coolant temperature of -25°C, an extension of the injection time of max. 100 % becomes effective depending on the engine speed, and this is reduced to "zero" by the time the operating temperature is reached. Furthermore, the magnitude of the control current for the idle stabilization valve (idling speed) and the variation of the firing point are determined.

The sender signal is also used for the:

- o Cold start enrichment up to 60°C
- o Acceleration enrichment (over the entire temperature range)
- o After-start enrichment (over the entire temperature range)
- o Overrun fuel cut-off > 50°C
- o Position of the idle stabilization valve during start-up

Note:

If the signal is interrupted whilst the engine is operating, the Digifant control unit switches back to the set basic firing point and no adjustment of the firing point occurs. If interruption occurs before starting up, the Digifant control unit switches over to the assigned map value for the warm engine (> 60°C). For the basic engine settings for firing point, idle speed and CO-content, the plug should be disconnected from the coolant temperature sender.

Pressure sensor

A piezo-resistive semiconductor sensor is used to measure the engine load. "Piezo-resistive" means that the resistor functions pressure-dependently. It is integrated into the control unit and is actuated by the current intake manifold pressure via a hose line to the intake manifold. The pressure sensor is designed as an absolute pressure sensor and has a measuring range of approx. 0 - 2 bar. The detected engine load relates to the current absolute intake manifold pressure. For this reason, changes in the atmospheric pressure, e.g. when driving in mountainous regions, have no influence on the mixture composition.

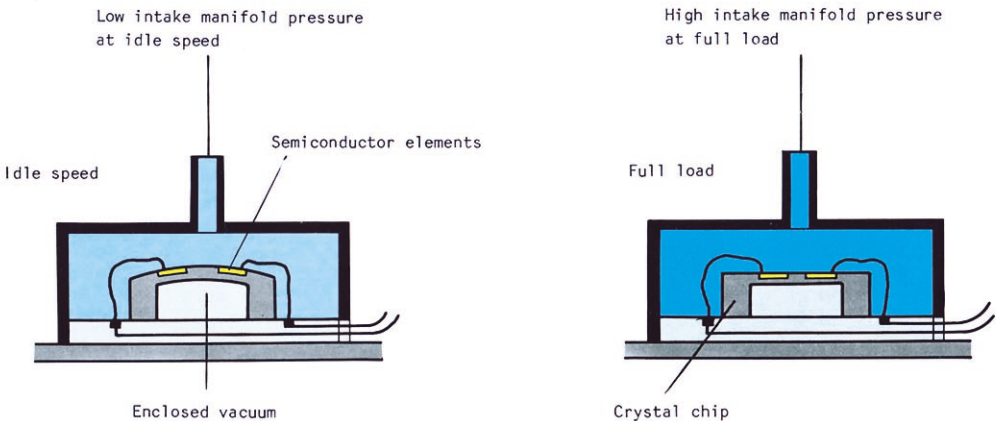

This representation is considerably simplified and is much larger than actual size

This is the actual size of the chip

It works like this:

The actual measuring element is a silicon crystal chip mounted on a baseplate. Enclosed within it is a tiny vacuum. This forms the basis for the measurement of the intake manifold pressure. The dimensions of the chip are such that the surface represents a defined diaphragm. On this diaphragm are several resistors connected to a circuit. These resistors have the property that they vary their electrical resistance as they are deformed.

The variation in resistance serves as a signal to the microprocessor in the control unit and is used in conjunction with the engine speed signal to determine the firing point and the injection time. The signal is also used for boost pressure control and acceleration enrichment.

Note: If the signal is interrupted or a short circuit occurs, the control unit switches over to an "emergency programme". In relation to the firing point and the injection time, this "emergency programme" corresponds to average engine load and speed.

Ignition distributor

An ignition distributor is used without centrifugal timing and vacuum control. The Hall sender delivers a voltage signal to the Digifant control unit at 78° crank angle before TDC and 6° crank angle before TDC per cylinder. These signals are used for the:

- o Ignition and dwell angle control
- o Injection duration
- o Idle stabilization
- o Engine speed limiting

Note: The engine cannot operate without a Hall signal.

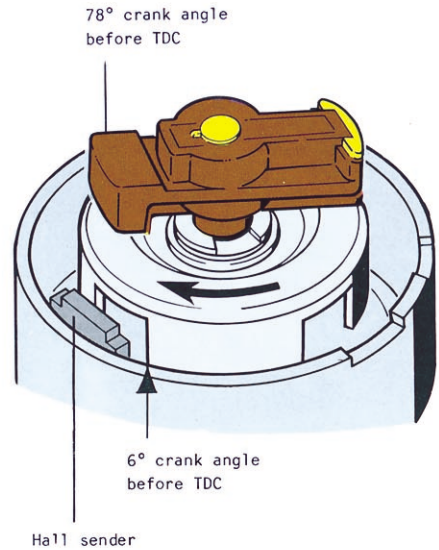

Throttle valve switch

The idle and full-load switches supply information to the Digifant control unit on the throttle valve position. The idle switch is closed at rest and supplies an earth signal at terminal 11 of the connecting plug to the control unit.

The full-load switch is open at rest. In full-load operation, it is closed and supplies an earth signal at terminal 15 of the connecting plug to the control unit.

The signal from the idle switch is used for the:

- o Idle stabilization
- o Overrun fuel cut-off
- o Ignition characteristic curve in overrun

The signal from the full-load switch is used for the:

- o Full-load enrichment (from 2250 rpm)

Note: If the signal is interrupted by the idle or full-load switches, the above functions cannot be activated.

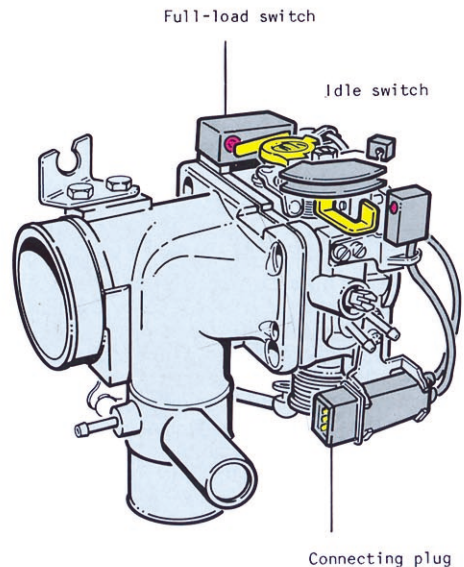

Knock sensor

The knock sensor with integral steel bush known from other systems is used. The steel bush provides better transmission of vibration to the piezo element and protects the knock sensor from deformation.

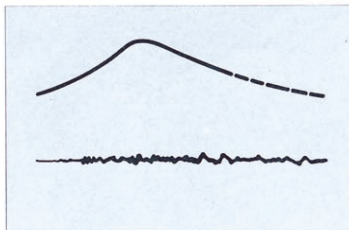
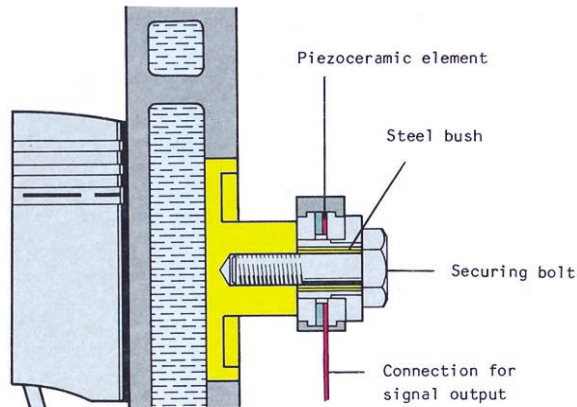

Regular combustion process

Combustion pressure

Knock sensor signal

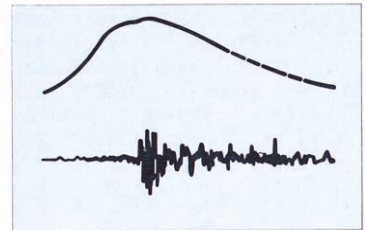

Irregular combustion process

It works like this:

The knock sensor functions according to the piezoelectric principle in which the enclosed piezoceramic element converts any vibration occurring in the engine into electrical voltage signals by means of its own deformation. The voltage signals form the basis for correcting the current "knock firing point" for the control unit. The magnitude of these voltage signals (max. 3 - 4 V) depends on the intensity of the vibrations in the engine which are dictated by the regularity or irregularity of the combustion process.

Knocking combustion processes cause vibrations in the engine block between 7 - 12 kHz. Since however, auxiliary units also generate vibrations in this frequency range, the "hearing" of the knock sensor has been restricted for irregular combustion processes to approx. 12 kHz. This restricted "hearing" was achieved by using a new cap (anti-freeze) in the engine block to which the knock sensor is attached.

Note: If the signal is interrupted, no injection occurs from an engine load of approx. 1 bar.

Sender for intake air temperature with CO potentiometer

The sender for intake air temperature (G42) and the CO potentiometer (G74) are incorporated into a single component.

The sender for intake air temperature is designed as an NTC resistor. A change in the intake air temperature is directly related to the air density. This effect is used to correct the injection time and for the mixture formation from -24°C to 100°C intake air temperature.

At -24°C intake air temperature, the injection time is extended by 25 % and this is reduced to "zero" as the intake air temperature increases (max. 100°C).

The CO potentiometer permits a basic setting of the engine. According to setting, it supplies a resistance value from 0 - 2 kohms to the Digifant control unit. According to the resistance value of the CO potentiometer, the entire map is increased/decreased for the injection time (only if the setting conditions according to the Workshop Manual are fulfilled).

In the idle speed range, the influence on the injection time due to the change in the CO potentiometer is at its greatest and extends from +25 % to -20 %; in the part-load range, from +10 % to -10 %. Depending on the load information from the pressure sensor, no change in the injection time occurs in the full-load range.

Note:

The sender for intake air temperature and the CO potentiometer are tested in a plausibility test to check whether their output signals lie within the specified range. If a fault is present, the appropriate signal is replaced by a stored fixed value. For the intake air temperature sender 45°C and for the CO potentiometer 1 kohm.

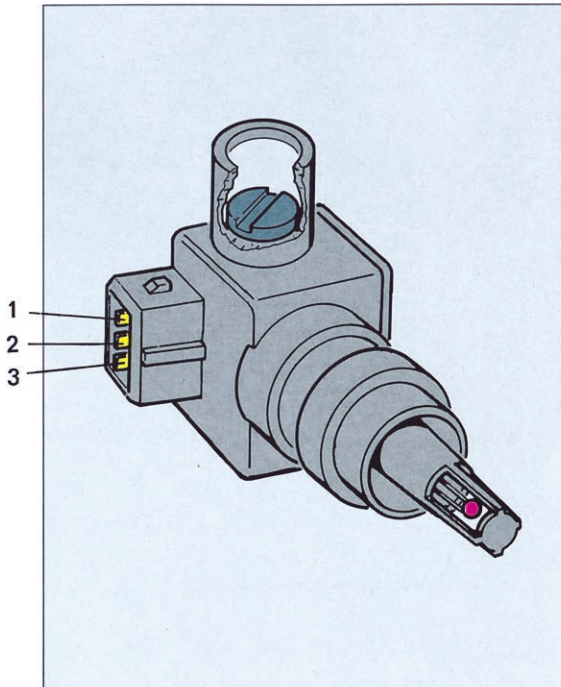

Contacts 2 + 3 for
resistance value from
intake air temperature sender

Contacts 1 + 3 for
resistance value from
CO potentiometer

In conjunction with the three-way catalyst, the lambda control represents the most effective exhaust purification process currently available for the petrol-injection engine.

The three critical exhaust components, hydrocarbons (HC), carbon monoxide (CO) and nitrogen oxides (NO_x) can be reduced by more than 90 % if the engine is operated with a precisely defined fuel-air mixture (corresponding to the air ratio λ (lambda) = 1).

Only with the closed control circuit, the lambda control, is it possible to maintain the fuel-air mixture within the range of lambda = 1 (catalyst window) under all operating conditions.

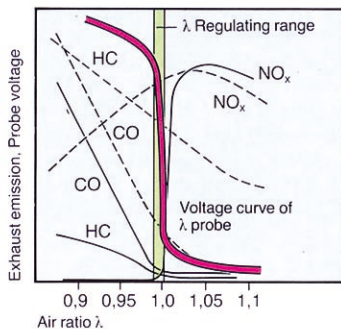

--- Without catalytic treatment
 — With catalytic treatment

Lambda probe

The front part of the lambda probe contains the active probe ceramic element. Whilst the outer part of the probe ceramic element is situated in the exhaust stream, the inner part comes into contact with the surrounding air. The surfaces of the probe ceramic element are fitted with electrodes of a gas-permeable platinum coating. A porous ceramic layer has been applied to the side exposed to the exhaust to protect it against combustion residues. From 300°C, the probe ceramic element becomes conductive for oxygen ions (ions = electrically charged atoms/molecules). If the oxygen content is different on both sides, an electrical voltage is produced due to the materials used.

Depending on the residual oxygen content (mixture composition) of the exhaust gas, the lambda probe sends the voltage signal between 100 - 1000 mV to the control unit which is required for control.

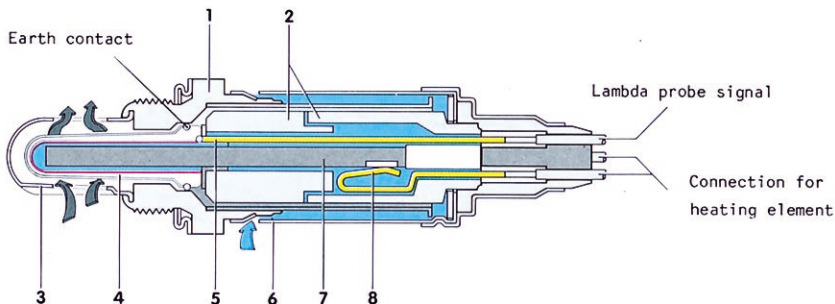

1. Probe housing, 2. Ceramic support pipe, 3. Protective tube with slits, 4. Active probe ceramic element
5. Contact, 6. Protective sleeve, 7. Heating element, 8. Clamps for heating element

The heated lambda probe used in the Digifant engine management system means that it can be installed further from the engine so that even long-lasting full-load journeys are unproblematic and the temperatures of approx. 930°C, which considerably influence the service life, are not exceeded. Due to the integral heating element, the lambda control is already active after 20 - 30 secs. (when the minimum operating temperature of 300°C is reached).

G-supercharger

An increase in power can be achieved by various measures.

The decision regarding the 1.8 ltr. engine with Digifant was made in favour of supercharging and Volkswagen favoured the G-supercharger as the ideal mechanical system. The G-60-supercharger was preferred to other supercharger systems because it supplies approx. 30 - 50 % more torque in the lower and medium engine speed ranges without delay. At engine speeds from 2400 to 5700 rpm, a torque of more than 200 Nm is available. Without mechanical supercharging, at least 2.5 litres capacity would be required to achieve so much torque.

Left housing half

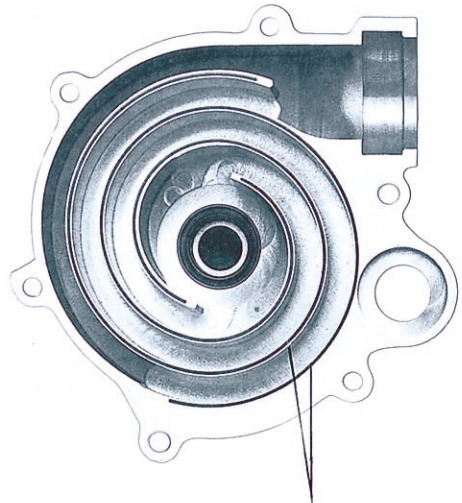

Sealing connectors

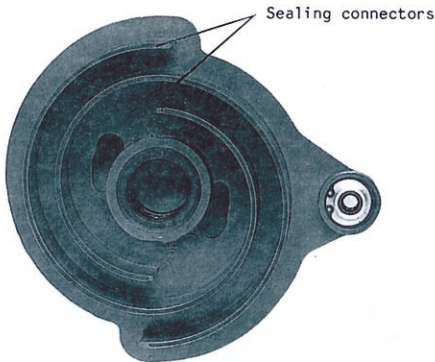

Displacer element

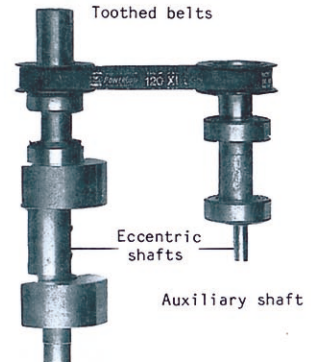

Drive shaft

The G-supercharger is based on a so-called spiral supercharger patented by the Frenchman L. Creux in 1905. Despite considerable advantages, such as good efficiency, low operating noise and wear, the G-supercharger remained unbuilt for a long time for manufacturing reasons. The precision light-metal casting technique and processing of both housing halves from aluminium and the processing of the displacer element from magnesium were developed to mass production by Volkswagen. Particular precision is demanded in the manufacture of the displacer element. Each housing half contains two spiral chambers. The baseplate of the displacer element with its 60 millimetre wide G-shaped spirals connects separately functioning left and right charging chambers.

Right housing half

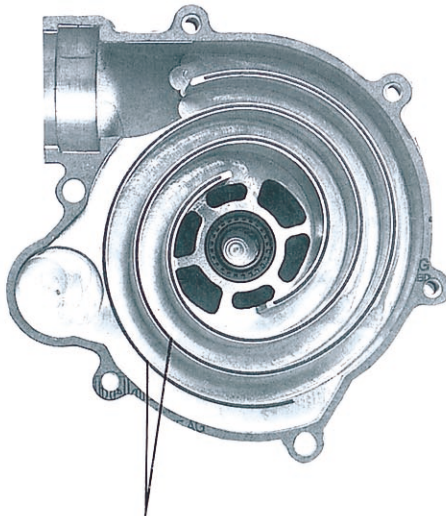

Sealing connectors

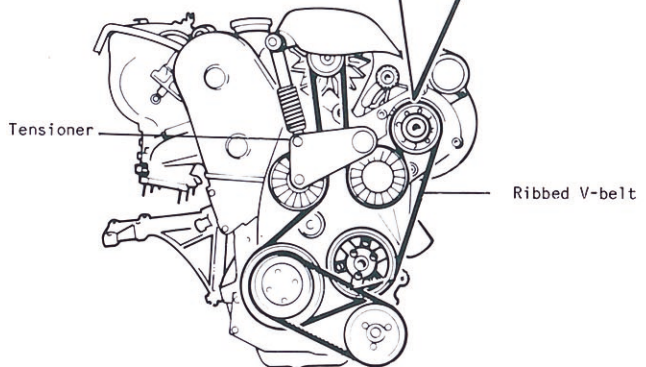
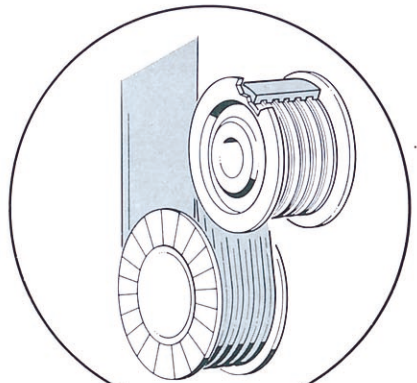

It works like this:

The drive shaft of the G-supercharger is driven by the crankshaft flywheel by the ribbed V-belt. The drive shaft and the auxiliary shaft are connected via a toothed belt. The evenly eccentric operating movement of the displacer element in the supercharger housing is achieved by means of the eccentric shaft of the drive and auxiliary shafts.

All spiral contours are equipped with sealing connectors which are also responsible for guidance in an axial direction. Due to the low relative speeds between the displacer element and the housing, a long service life of the sealing connectors is guaranteed.

- Technical data:
- o Supply volume 860 cm³ per revolution
 - o Rated speed 10 000 rpm
 - o Max. charge pressure 0.7 bar

Note: The sequence of movements and the air displacement within the G-supercharger are described in the In-dealership training material (video) Corrado No. 383.

To facilitate dismantling of the ribbed V-belt, the tensioner can be untensioned with special tool V.A.G 1391.

Charge air cooling

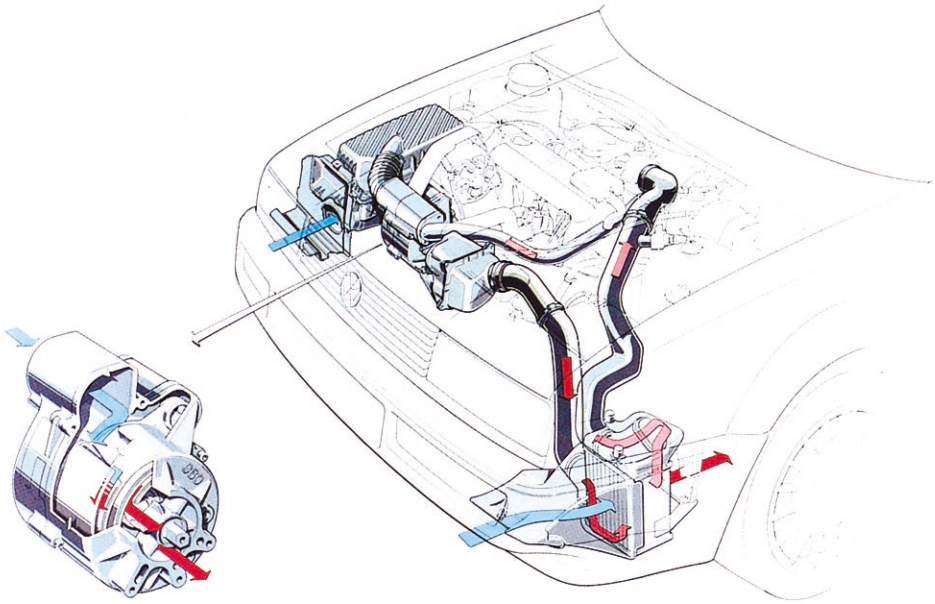

It works like this:

The intake air is directed through the air filter to the G-supercharger. In the G-supercharger, the air stream is accelerated and condensed and then directed to the charge air cooler.

According to the external and engine temperatures, the pre-condensed air reaches up to 150°C before the charge air cooler.

In the charge air cooler, the air is cooled by approx. 55°C depending on the operating conditions. With the cooler (more dense) air, more oxygen enters the combustion chambers which simultaneously leads to improved filling and increased power and also reduces the tendency for knocking.

Bypass circuit

In the part-load range, the G-supercharger supplies far too much air than the engine requires for this operating condition. For reasons of fuel consumption, it does not make sense to increase the charge pressure only to reduce it again subsequently to the desired power level with the throttle valves. For this reason, the excess air quantity supplied by the charger is returned without pressure to the supercharger intake side via a controlled bypass line. This can considerably improve the fuel consumption.

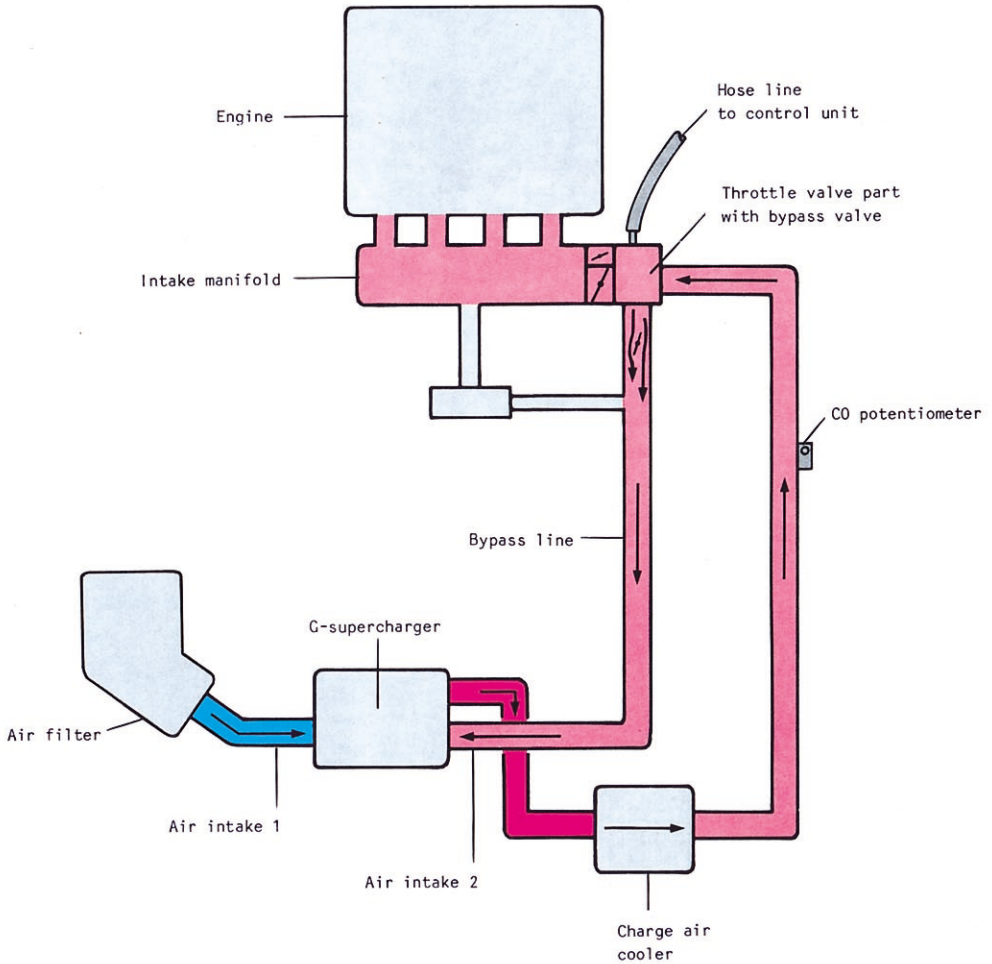

It works like this:

Surplus air travels via the bypass valve and bypass line to air intake 2 of the G-supercharger. The bypass valve is controlled via a linkage to the throttle valves. The throttle valve functions in the opposite direction to the bypass valve. This means that, when the throttle valves are fully open, the bypass valve is closed and when the throttle valves are closed, the bypass valve is open.

"Emergency function"

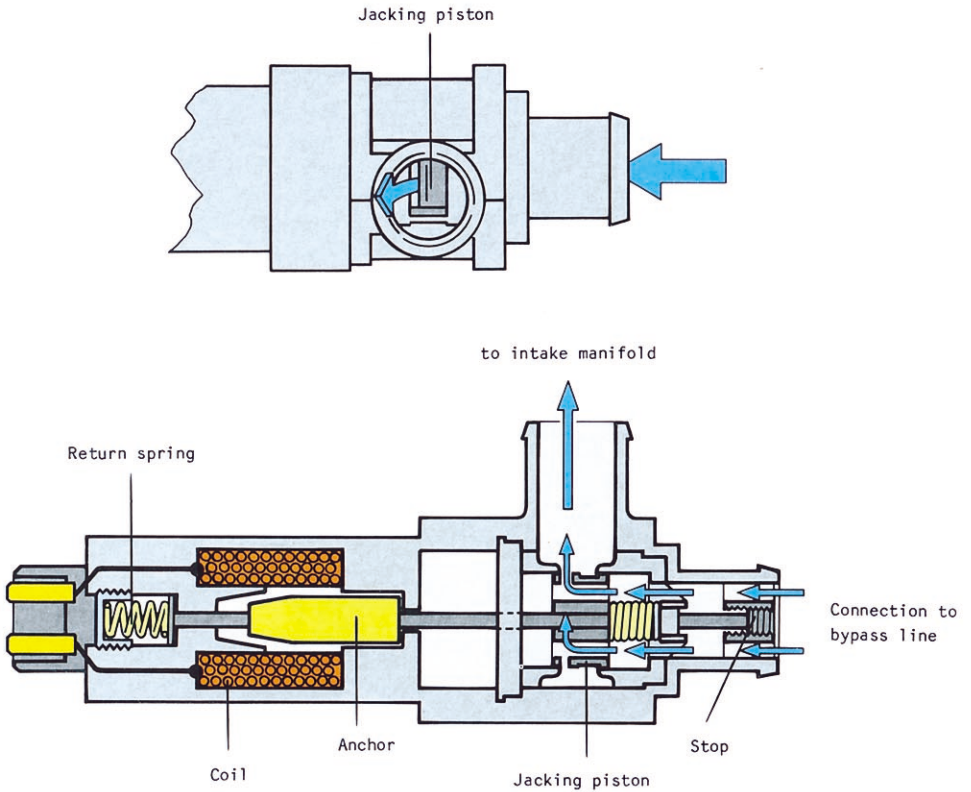

If the idle stabilization valve fails, the return spring presses the jacking piston to a stop so that the opening provided by the jacking piston remains constant. The engine speed then corresponds approximately to the warm idle speed and guarantees that the engine continues to operate in an emergency.

Boost pressure limiting system

The duty of the boost pressure limiting system is to limit the boost pressure depending on the engine speed and the frequency of knocks. The limiting and return of the boost pressure to the intake side (air intake 2) of the G-supercharger occurs via the idle stabilization valve. The idle stabilization valve is activated by the Digifant control unit; to do this, the control unit evaluates the voltage signals from the Hall sender (speed signal), the voltage signals from the knock sensor and the current charge pressure from the pressure sensor.

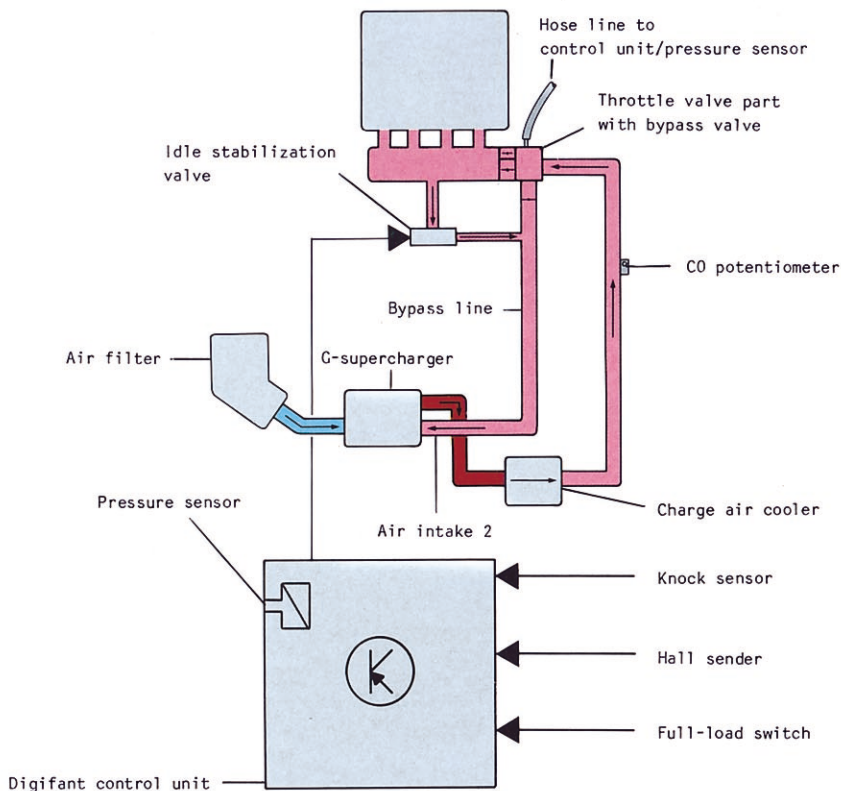

It works like this:

From an engine speed of 5600 rpm (max. power) until the switch-off speed of 6200 rpm is reached, the boost pressure is reduced by 0.1 - 0.15 bar. This results in a more gentle "entry" into the switch-off speed.

However it is more important to limit the boost pressure at an increased frequency of knocks (in addition to the firing angle reduction). Depending on the frequency of knocks, the boost pressure is restricted to max. 0.4 bar. This restriction prevents any exceeding of critical exhaust gas temperatures.

Note on the full-load signal:

If the load suddenly changes from idle speed to full-load operation, the idle stabilization valve closes momentarily whereby the transition behaviour is improved and the boost pressure is increased more rapidly. The spontaneous closing of the idle cross section of the idle stabilization valve occurs due to the earth signal from the full-load switch via the Digifant control unit.

Boost pressure limiting system

The duty of the boost pressure limiting system is to limit the boost pressure depending on the engine speed and the frequency of knocks. The limiting and return of the boost pressure to the intake side (air intake 2) of the G-supercharger occurs via the idle stabilization valve. The idle stabilization valve is activated by the Digifant control unit; to do this, the control unit evaluates the voltage signals from the Hall sender (speed signal), the voltage signals from the knock sensor and the current charge pressure from the pressure sensor.

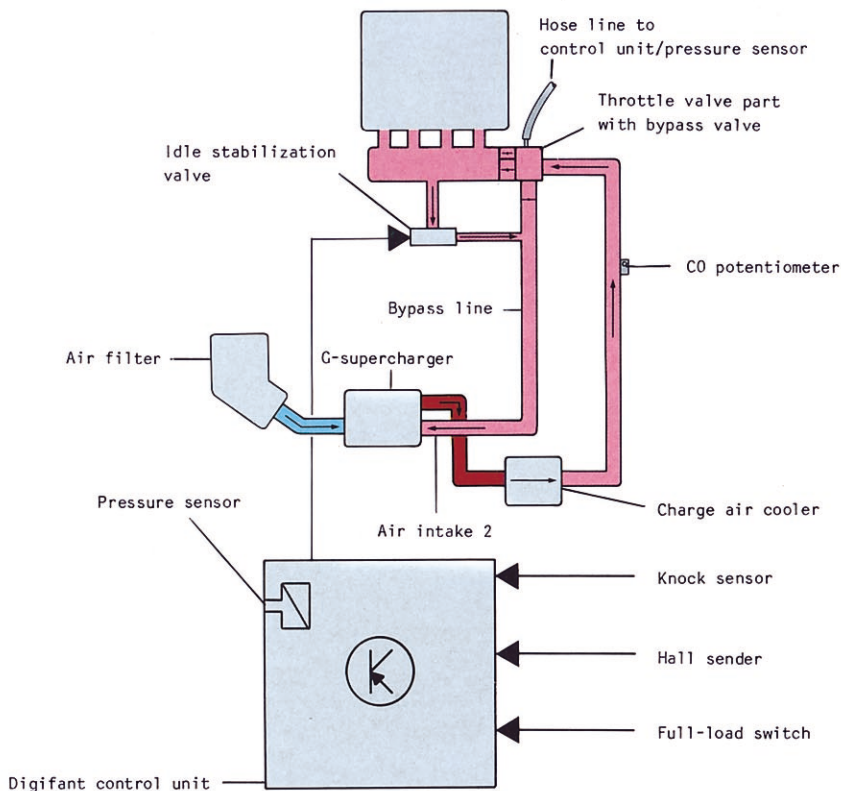

It works like this:

From an engine speed of 5600 rpm (max. power) until the switch-off speed of 6200 rpm is reached, the boost pressure is reduced by 0.1 - 0.15 bar. This results in a more gentle "entry" into the switch-off speed. However it is more important to limit the boost pressure at an increased frequency of knocks (in addition to the firing angle reduction). Depending on the frequency of knocks, the boost pressure is restricted to max. 0.4 bar. This restriction prevents any exceeding of critical exhaust gas temperatures.

Note on the full-load signal:

If the load suddenly changes from idle speed to full-load operation, the idle stabilization valve closes momentarily whereby the transition behaviour is improved and the boost pressure is increased more rapidly. The spontaneous closing of the idle cross section of the idle stabilization valve occurs due to the earth signal from the full-load switch via the Digifant control unit.

Ignition control

In order to reduce electromagnetic interference values/frequencies, the power output stage has been integrated into the Digifant control unit. It regulates and limits the current required to build up the ignition voltage depending on the operating condition. A control of the dwell angle also occurs.

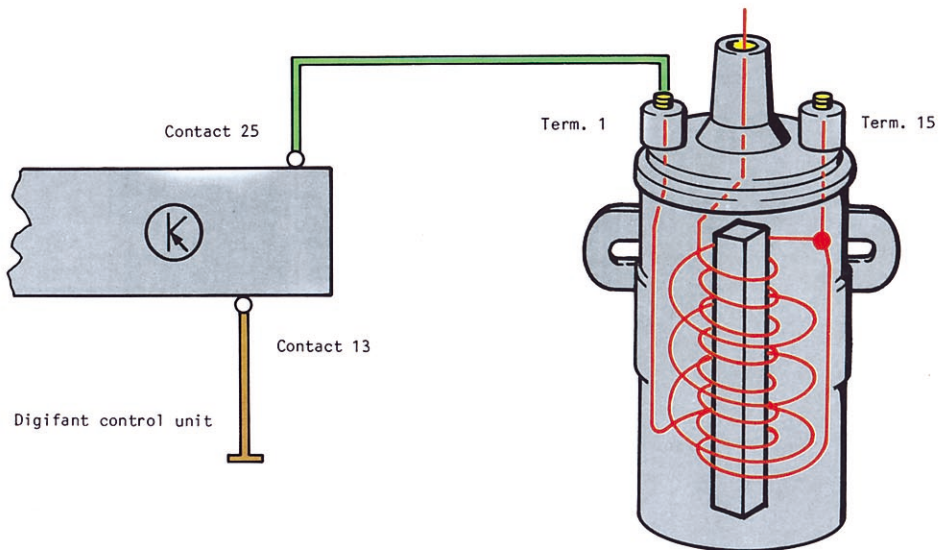

The primary current is limited to approx. 7.5 amperes by the power output stage. The dwell angle control switches the primary current so that 7.5 amperes is reached at the firing point and the greatest possible ignition energy is available for each operating condition.

Ignition control

The ignition map and the knock control make it possible to separately determine the firing point for each cylinder and for each timing. In conjunction with the boost pressure limiting system, this technique enables the driver to operate the vehicle with very low power loss even using unleaded regular fuel (at least 91 RON). Depending on the operating conditions of the engine, the appropriate firing point is assigned.

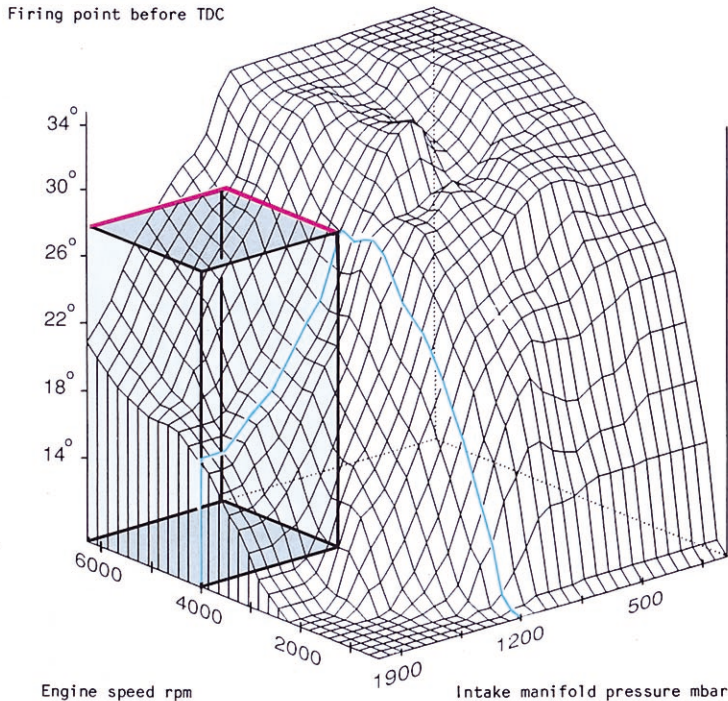

As the engine speed increases, the firing point is always advanced. However, as the engine load increases the magnitude of the advance decreases. A three-dimensional representation of the ignition map clarifies the large number of possible firing points; here, for the sake of "readability" of the diagram, it is based on an engine speed of 4000 rpm and an intake manifold pressure of 1.2 bar.

The firing point is determined by the Digifant control unit according to pre-programmed values corresponding to the evaluated sensor signals.

- o Pressure sensor to detect engine load
- o Coolant temperature sender as correction for cold engine up to 10° crank angle in direction "advance"
- o Knock sensor for knock control
- o Hall sender for engine speed and firing angle assignment (78° to 6° before TDC)

Knock control

Optimum engine operation with simultaneous high efficiency under all operating conditions means that the control of the firing point should lie as close as possible to the knock limit.

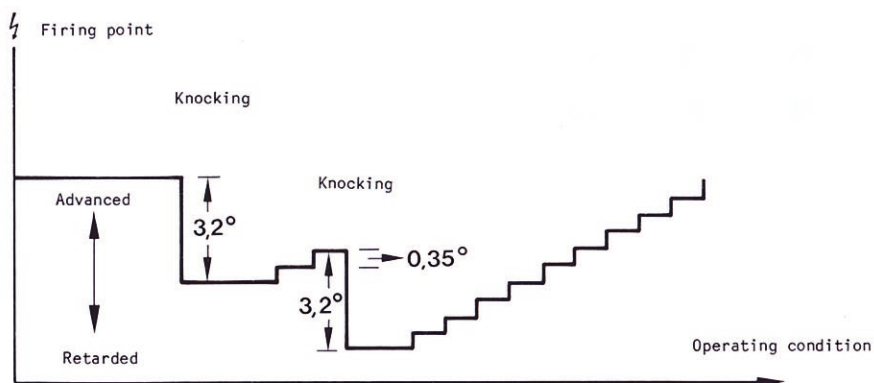

If knocking occurs in one cylinder, this is detected cylinder-selectively by the Digifant control unit. The control unit retards the firing point for the appropriate cylinder by 3.2° . If the knocking is eliminated the firing point is advanced again in stages of 0.35° until the pre-programmed map value is reached. If the knocking continues or re-occurs, the firing point for each cylinder can be retarded by up to 12.5° . If the sum of the ignition angle retards of all cylinders is more than 20° for a period of more than 8 secs., the boost pressure is restricted to 1.5 bar.

Fan and fuel pump run-on

Relay location assignment

- 12** - Fuel pump relay (80)
- 13** - Relay for fuel pump run-on (90)
- 14** - Control unit for fan run-on (31)

Note

The brackets after the part designations refer to the production control number on the housing

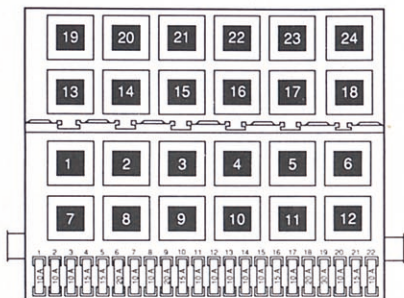

Fuse colours

- 30 A - green
- 25 A - white
- 20 A - yellow
- 15 A - blue
- 10 A - red

It works like this:

To reduce "warm start" and "warm drive-away problems", a fan and fuel pump run-on is used in the 1.8 ltr. engine with G-60-supercharger.

The fan and fuel pump run-on is only effective when the engine is switched off and "ignition off".

At ambient temperatures of over 90°C, the thermo switch F87 (located between the idle stabilization valve and the pressure regulator) connects ground to the control unit for radiator fan run-on (J138). Due to this earthing, the control unit produces a positive connection between connection 4/30 and 8/87. The coolant fan runs at the 1st stage. At the same time, connection 5/L of the control unit for fuel pump run-on (J206) is activated.

After approx. 2 mins. the control unit for fuel pump run-on (J206) closes the working-current contact between connections 2/30 and 8/87 if a minimum holding pressure of 1.2 bar is detected by the pressure switch F130 and there is continuity between connections 5/L and 1/P. (If there is no pressure, switch F130 is open.) The time delay of 2 mins. and a minimum requirement on the holding pressure of 1.2 bar prevents the fuel pumps operating if there are leaks in the fuel system.

The times for both run-on functions are restricted by an integrated timing element in the control unit for fan run-on (J138) to max. 10 mins.

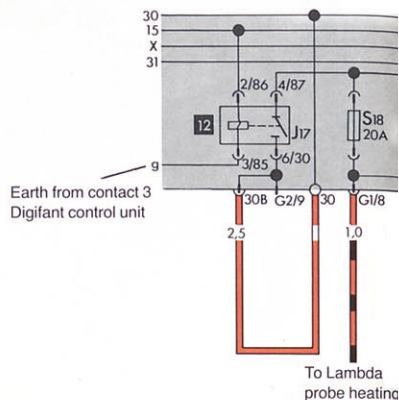

Only for use within the V.A.G Organization.
© VOLKSWAGEN AG, Wolfsburg.
All rights reserved. Technical specifications subject to alterations.
800.2809.20.20 Technical status February 1989